

# TFT Large Display Wi-Fi Weather Station

## With Ultrasonic Anemometer Sensor Package and Rain Gauge Sensor Operation Manual Model: HP2553

Thank you for purchasing this HP2553 TFT Large Display Wi-Fi Weather Station, a complete weather station with ultrasonic anemometer and independent self-emptying rain gauge.

This manual will guide you, step-by-step, through setting up your weather station and base unit, and understanding the operation of your weather station.



**Note:** The mounting poles for anemometer sensor package and rain gauge sensor are **not included**.

# 1 Table of Contents

1 Table of Contents.....	2
2 Unpacking.....	5
3 Overview .....	7
3.1 Display Console.....	7
3.2 Indoor sensor .....	9
3.3 Ultrasonic anemometer with 6-in-1 sensors.....	10
3.4 Rain Sensor.....	10
3.5 Features.....	11
4 Set up Guide .....	14
4.1 Site Survey.....	14
4.2 Ultrasonic Anemometer package assembly.....	15
4.2.1 Install batteries in sensor package .....	16
4.2.2 Mount ultrasonic anemometer assembly .....	17
4.2.3 Reset Button and Transmitter LED .....	21
4.3 Rain Gauge Sensor Set Up and Installation .....	21
4.3.1 Install rain gauge filter .....	22
Figure 14: Rain gauge filter in/un-installation diagram.....	23
4.3.2 Install rain collector top .....	23
4.3.3 Install Batteries in rain gauge sensor.....	24
4.3.4 Mounting.....	24
4.4 Indoor Sensor Set Up.....	26

4.4.1 Sensor Placement .....	27
4.5 Best Practices for Wireless Communication .....	28
4.6 Console Display.....	29
4.6.1 Initial Display Console Set Up.....	32
4.6.2 Key functions.....	33
4.6.3 Main interface icons explain .....	34
4.7 Multiple Channel Selection and Scroll Mode .....	36
4.8 History Mode.....	37
4.8.1 View and Reset MAX/MIN .....	37
4.8.2 History Record Mode.....	38
4.8.3 Graph Mode .....	41
4.8.4 Optional Sensor Display Mode .....	43
4.9 Setting Mode.....	43
4.9.1 Date and Time setting .....	45
4.9.2 Time Format setting .....	46
4.9.3 Date Format setting.....	47
4.9.4 Temperature unit setting .....	47
4.9.5 Barometric unit .....	47
4.9.6 Wind speed unit .....	47
4.9.7 Rainfall unit .....	47
4.9.8 Solar Rad. Unit .....	47
4.9.9 Multi Channel Sensor.....	47
4.9.10 Backlight setting .....	50

4.9.11 Longitude: Latitude setting .....	51
4.9.12 Week Start Set .....	52
4.9.13 Rainfall season (default: January) .....	52
4.9.14 Storing Interval (1-240minutes Selectable).....	53
4.9.15 Weather Server.....	53
4.9.16 Connect Console to Your Router: Wi-Fi scan.....	70
4.9.17 Background.....	73
4.9.18 Alarm Setting Mode.....	74
4.9.19 Calibration Mode .....	75
4.9.20 More.....	80
4.9.21 Factory reset.....	84
5 Other Console Functions .....	87
5.1 Beaufort Wind Force Scale.....	87
5.2 Weather Forecasting .....	88
5.3 Lightning Alert .....	89
5.4 Weather Forecasting Description and Limitations .....	89
5.5 Moon Phase .....	90
6 Maintenance .....	92
7 Troubleshooting Guide .....	94
8 Specifications.....	98
9 Warranty Information .....	101

## 2 Unpacking

Open your weather station box and inspect that the contents are intact (nothing broken) and complete (nothing missing). Inside you should find the following:

<b>QTY</b>	<b>Item Description</b>
1	Display Console
1	Indoor sensor unit(temp/humidity/pressure)
1	Solar powered ultrasonic anemometer with Light and UV, air temperature/humidity sensor integrated( optional heater for climate with snow/ice conditions available)
1	Rain gauge
2	U-Bolts set for mounting on a pole (2pcs/set)
2	Threaded nuts for U-Bolts set (M6 size) (4pcs/set)
1	Metal mounting plate set to be used with U-Bolts (1pcs/set)
1	Mounting arm for ultrasonic anemometer (random color)
1	Mounting bracelet for ultrasonic anemometer (random color)
1	Mini wrench for M6 bolts
1	Stainless steel filter for rain gauge collector
1	AC adapter for display console
1	User manual (this manual)

**Table 1: Package content**

If any component is missing from the package, or broken, please contact our Customer Service department to resolve the issue.

**Note:** The console operates using an AC adapter. The included adapter is a switching-type adapter and can generate a small amount of electrical interference with the RF reception in the console, when placed too close to the console. Please keep the console display at least 2 ft. or 0.5 m away from the power adapter to ensure best RF reception from the outdoor sensor package.

**Note:** The console can store historical data on a memory card. This memory card is **not included**. If you want to use one you will need a microSD memory card. The supported max capacity of the card is 32G(Format: FAT32). A 1GB card will store more than 10 years' data. There is also no requirement on the speed class of this card as data writing happens infrequently and is not speed critical.

**Note:** Batteries for the ultrasonic anemometer and the rain gauge sensor are not included. You will need 2 AA size Lithium battery for the ultrasonic anemometer, which is primarily for startup and backup purpose. After setup and during normal operation, the unit is getting its power from solar cell. One AA size battery, alkaline or Lithium (recommended for colder climates) is required for the rain gauge. Two AA size alkaline batteries are required for the indoor sensor.

**Note:** There are two sets of U-bolts in the box, one is for the ultrasonic anemometer sensor and the other one is for the rain gauge sensor.

# 3 Overview

## 3.1 Display Console

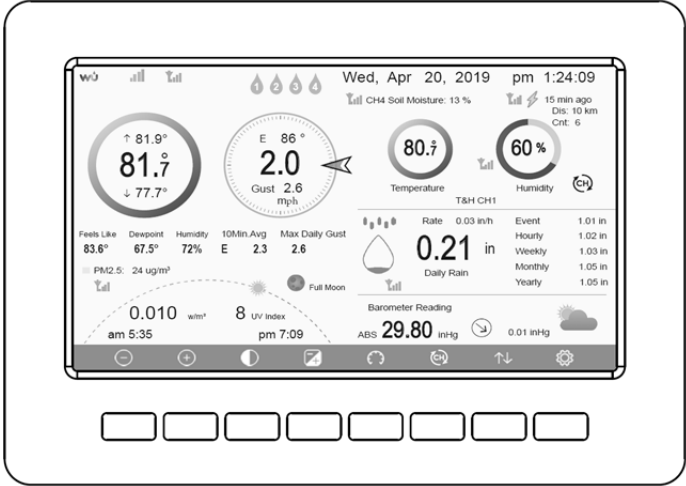

**Figure 1: Display console screen**

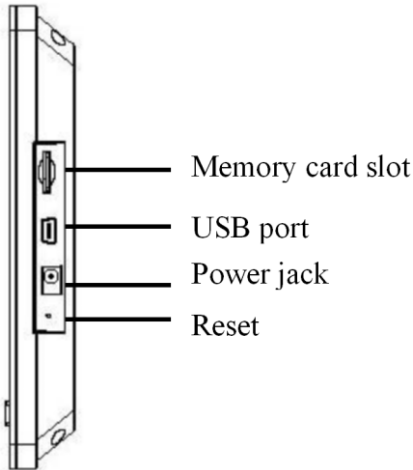

**Figure 2 Display console side views**

**Note:** The USB port in the console is only for factory internal use, not available for users.

You can use a micro SD card (max 32G, Fat 32) for the firmware update.(SD card not included).

Update firmware process:

- 1.Visit [www.ecowitt.com](http://www.ecowitt.com) for available update
- 2.On the navigation bar, select Manual & Firmware under Support
- 3.Search "HP2553" - find the firmware option and download it on your computer
- 4.Take out your micro SD card from the console
- 5.Drag the unzipped file(user.bin) under the root directory of your micro SD card.
6. Insert the card into the console - power off the console - power on the console - update the program.



### 3.2 Indoor sensor

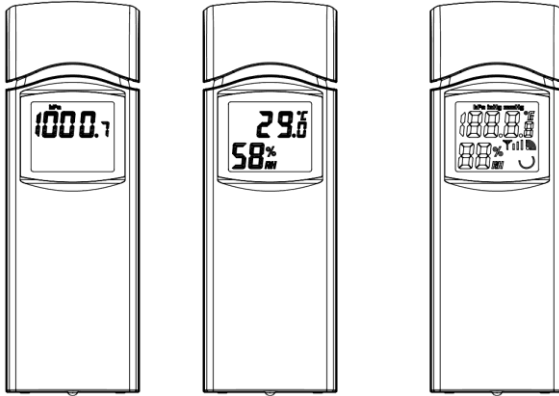

**Figure 3: Indoor sensor 2 display variations**

The indoor sensor will display indoor temperature, humidity and barometric pressure alternately.

### 3.3 Ultrasonic anemometer with 6-in-1 sensors

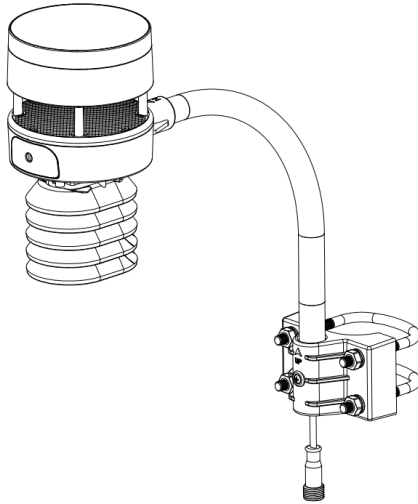

Figure 4: Solar powered ultrasonic anemometer with integrated solar & uv, thermo-hygrometer sensor

### 3.4 Rain Sensor

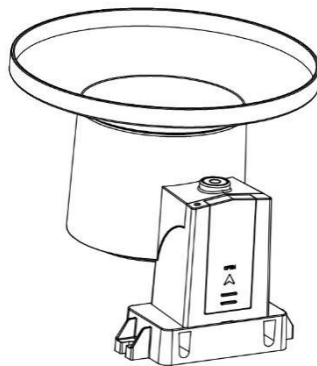

Figure 5: Self emptying rain gauge

### 3.5 Features

- 7" large TFT (high resolution) colored display console
- Two background (dark/light) themes selectable
- Indoor temperature, humidity
- Absolute and Relative barometric pressure
- Wind speed, wind direction, rainfall, outdoor temperature and humidity, solar radiation and UV.
- Calculates dew point, wind chill, heat index, moon phase and sunset/sunrise time
- Weather forecast & alarm
- View historical records of sensors and graph directly on the console
- Collects sensor data from various supported wireless sensors.
  - Additional/optional sensors:
    - Up to 8 WH31 multi-channel temperature and humidity sensors  
Or 8 WH30 multi-channel temp sensors
    - Up to 8 WN34 Temperature Sensors
    - Up to 4 WH41/WH43 PM2.5 air quality sensors
    - One WH45 PM2.5/PM10/CO2/temperature and humidity all-in-1 sensor
    - Up to 8 WH51 soil moisture sensors
    - Up to 4 WH55 water leak sensors
    - One WH57 lightning sensor
    - Future sensors to be developed
- Pushes sensor data to cloud weather services:
  - <https://www.ecowitt.net>
  - <https://www.wunderground.com>
  - <https://www.weathercloud.com/>
  - <https://www.wow.com>
  - Custom own server data hosting possible when server data exchange is compatible with either Wunderground or Ecowitt protocol.
- Manage sensor calibration setup.

- Manage sensor via sensor ID.
- Data storage service on Ecowitt server: <https://ecowitt.net>
  - Data storing interval:
    - by day: 5 minutes
    - by week: 30 minutes
    - by month: 4 hours
    - by year: 1 day
  - Stores data for past three months at 5-minute intervals
  - Stores data for past one year at 30-minute intervals
  - Stores data for past two year at 4-hour intervals

**Note:** The optional sensors can be purchased separately. If more info needed, please visit our website: [www.ecowitt.com](http://www.ecowitt.com). Make sure to select the model of the units with the same RF frequency as your gateway (the frequency is different for various countries because of regulations).

**Note:** There's a built-in heat plate in the 6-in-1 sensor package body, if the lowest temperature at your place is below -3 °C, or 26.6 °F, and the weather is mostly snowy or rainy, then you may need to activate the heater by supplying a 12V/1A power (sold separately) to the sensor heating element for melting accumulated snow or ice, which can influence wind measurement accuracy significantly. Please contact us at [support@ecowitt.com](mailto:support@ecowitt.com) for the extension cord information (sold separately).

There's a built-in thermostat inside the anemometer sensor to control the power supply for the heat plate, which will automatically turn on below 0°C (30°F) and automatically turn off above 10°C (50°F).

**Note:** To pair the optional sensors with the HP2553 console, please follow the below operations:

1. Place the optional sensor next to the console(keep 5-10ft away from each other).
2. Install batteries on the sensor and wait for 1-2 minutes.
3. Check whether the console will pick up the sensor data automatically and display it on the screen.
4. If not, press the gear icon and go to Setup page - find More and enter its Setup page - find Sensors ID and enter its Setup page.
5. In the Sensors ID Setup page, find the sensor you want to pair - select the ID number box and register it.
6. Once successfully, you may return to the main interface to check the data.

## 4 Set up Guide

Before you start, you will need a Philips screwdriver (size PH0, not provided) and find the wrench (size M6) included in package.

**Note:** We suggest you assemble all components of the weather station, including base unit in one location so you can easily test functionality. After testing, place the outdoor sensors in the desired location. Note, however, that movement during assembly, and movement after assembly can cause the rain sensor to “falsely” register rain. It is possible to reset the rain total to 0 via WS View app.

### **Attention:**

- Follow the suggested order for battery installation (outdoor sensor(s) first, indoor sensor(s) second, optional base unit last).
- Ensure batteries are installed with correct polarity (+/-).
- Only use new batteries for all battery-operated sensors.
- Avoid rechargeable batteries being used.
- If outdoor temperature may go below 32 F or 0 C for prolonged periods, Lithium based batteries are suggested over alkaline type batteries for any outdoor sensor.

### 4.1 Site Survey

Location of various sensors is paramount to good data collection. Abbreviated instructions follow, but for a detailed reference, see: <https://www.weather.gov/media/epz/mesonet/CWOP-Siting.pdf>.

Perform a site survey before installing the weather station. Consider the following:

#### **Anemometer**

- Ideally mounted at least 32 feet, or 10 meters above ground level.

- Try to make the anemometer the highest object around. 7 feet, or 2.75 meters) or more above the surrounding obstructions is best.

## Rain Gauge

- Ideally mounted at a height of 4 to 6 feet, or 1.5 to 2 meters above the ground.
- Ideally located at a horizontal distance of 4 times the height, above the rain gauge, of the nearest obstruction.
- Ensure the rain gauge is mounted level to the ground, away from any horizontal surface that can introduce rain-splashing or surrounding snow buildup.

## 4.2 Ultrasonic Anemometer package assembly

See Figure 6 to locate and understand all the parts of the ultrasonic anemometer package with UV & light, thermo-hygrometer sensors, once fully assembled.

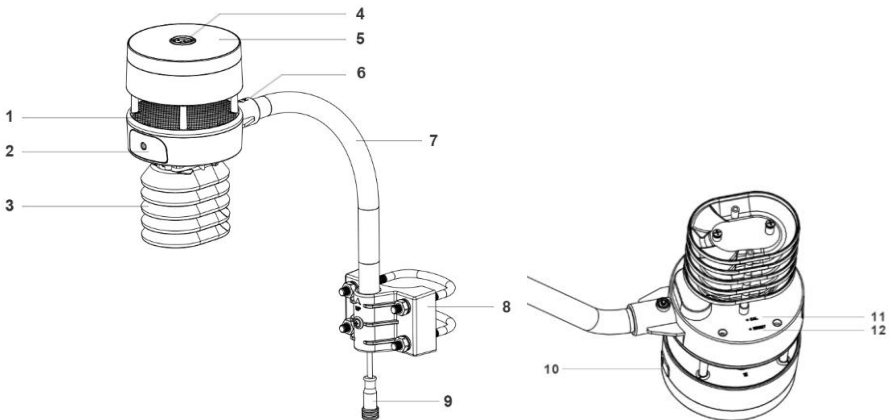

**Figure 6: Sensor package assembly components**

1. Surface tension conditioner layer ( patent pending)	7. Mounting arm
2. Battery compartment	8. Mounting bracelet and U-bolt set
3. Temperature & humidity sensor	9. Power cord for built-in heater
4. Light & UV sensor, LED indicator	10. USB port (factory use only )
5. Solar Panel	11. Calibration button (factory use only )
6. NORTH alignment indicator	12. Reset button

**Table 2: Sensor package assembly component list**

### **4.2.1 Install batteries in sensor package**

Open the battery compartment with a screwdriver and insert 2 AA batteries in the battery compartment, and press “Reset” button, the LED indicator on the back of the sensor package (item 4) will turn on for 3 seconds and then flash once every 4.8 seconds indicating sensor data transmission. If you did not pay attention, you may have missed the initial indication. You can always press the reset button to start over. Make sure you see the flash once every 4.8 seconds.

If sensor has been put outside for some time, and solar panel has charged up the internal accumulator fully or partially, if you install the 2 AA backup battery, the system might not start up properly. So you can always make a system reset by press the “Reset” button.



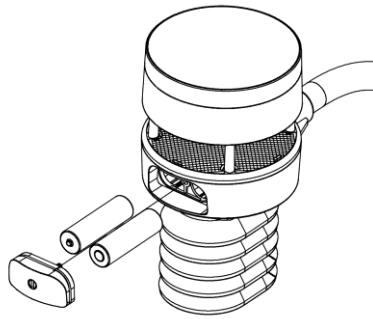

**Figure 7: Battery installation diagram**

**Note:** Please make sure the battery is inserted correctly for its polarity as the system needs its initial power from this backup battery to start up the system before solar panel charges up the accumulator and supply system power afterwards. when in high altitude area, during wintertime, sunshine time is short, thus system needs to be powered from this backup battery, we recommend **Lithium batteries** to be used for cold weather climates. Please avoid alkaline batteries, especially when internal heater is to be activated during cold and wet weather conditions as when heater activated, the trapped heat inside will warm up internally, and alkaline batteries are extremely susceptible to leakage when temperature is over certain limits.

## **4.2.2 Mount ultrasonic anemometer assembly**

### **4.2.2.1 Before you mount**

Before installing your outdoor sensor in the permanent location, we recommend operating the device for one week in a temporary location with easy access. This will allow you to check out all of the functions, ensure proper operation and familiarize you with the weather station performance.

### **4.2.2.2 Mounting**

- You can attach a pole(not included) to a permanent structure and then attach the sensor package to it (see Figure 8-12).
- The U-Bolts will accommodate a pole diameter of 1.25-2 inches (pole not included).

1. Install the base on a pole (1.25inch~2inch) as Figure 8.

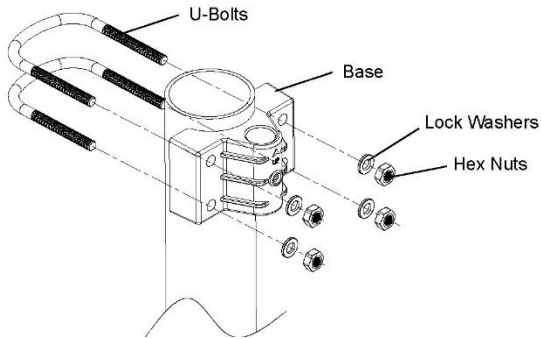

**Install each M6 nut in the order 1,2,3 then 4.**

Do not tighten with an impact driver.  
Hand tighten, then a half turn/180°  
No more. If your mounting pole  
is a soft material(wood, pvc, etc.)  
you may need to retighten the  
M6 nuts when you perform your  
maintenance every 3 months.

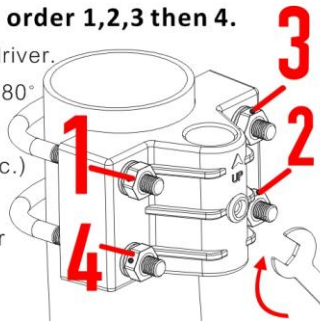

**Figure 8: Sensor package mounting diagram 5-1**

2. Pass the connector cord through the arm tube as Figure 9:

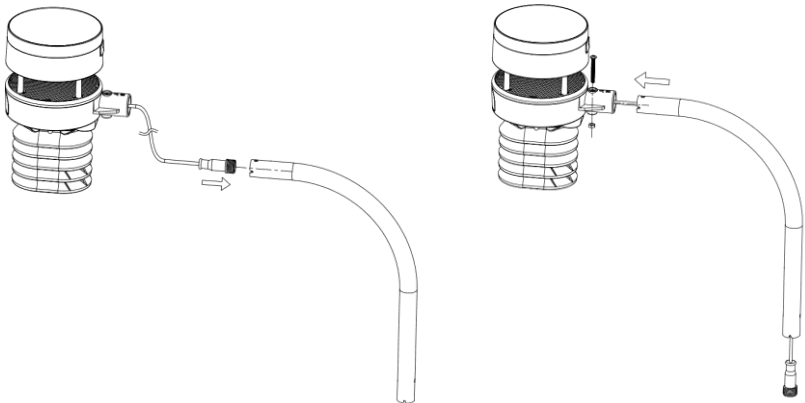

**Figure 9: Sensor package mounting diagram 5-2**

3. Attaching the arm tube to the Ultrasonic Sensor as Figure 10.

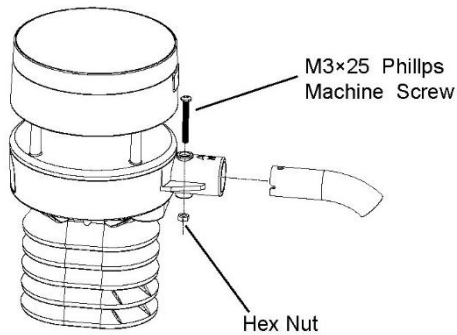

**Figure 10: Sensor package mounting diagram 5-3**

4. Insert the arm tube into the base as Figure 11. Be sure to line up the small hole in the arm with the holes in the base. Insert the machine screw through the holes in the base and arm. ( if you don't need to power up the heater, you should keep the power cord terminal inside the mounting arm and this can make the installation looks neat and tidy. You may take it out when needed.)

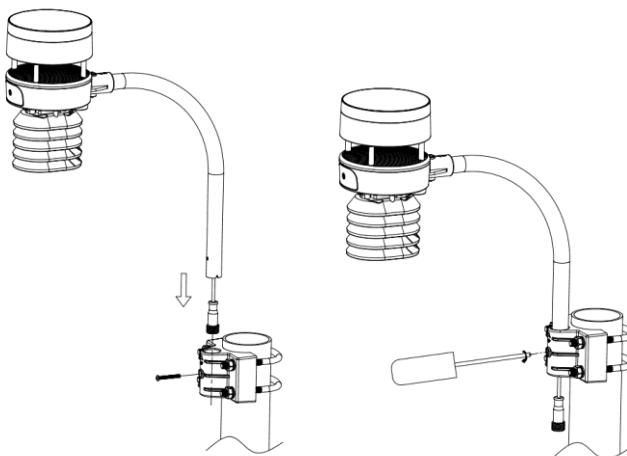

**Figure 11: Sensor package mounting diagram 5-4**

Make sure the mounting pole is vertical, or very close to it. Use a level as needed.

5. If optional extension cord is added, connect the cord to the connector and insert the USB port into the AC adaptor as Figure 10 show:

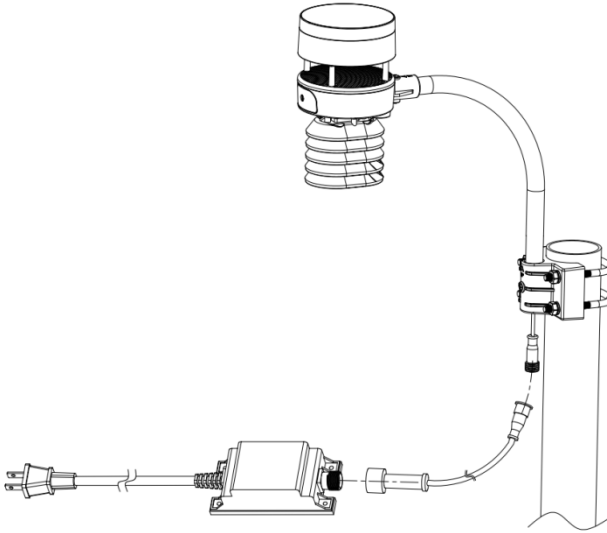

**Figure 12: Sensor package mounting diagram 5-5**

Finally, place the sensor package on top of the prepared mounting pipe. The U-Bolts should be loose enough to allow this but loosen the nuts as necessary. Once placed, hand tighten all four nuts, taking care to do so evenly. Do not use a wrench yet!

Now you will need to align the whole package in the proper direction by rotating it on top of the mounting pipe as needed. Locate the arrow labeled “NORTH” that you will find on top of the connector tube of the sensor package (item 6). You must rotate the whole sensor package until this arrow points due north. To achieve proper alignment, it is helpful to use a compass (many cell phones have a compass application). Once rotated in the correct orientation, lightly tighten the bolts a little more (use a wrench) to prevent further rotation.

**Note:** In Southern hemisphere, it is not necessary to change the orientation to SOUTH as its solar panel is a rounded type and it is orientation free for its charging capability.

Make sure the mounting tube for the sensor package is installed vertically (use a level at 90-degree offsets around the tube). Adjust the mounting pipe as necessary. Next also make sure the mounting of the anemometer body on the pipe is level. If it is not, wind direction and speed readings may not operate correctly or accurately. Adjust the mounting assembly as necessary.

Make sure you check, and correct if necessary, the north orientation again, as the final installation step, and now tighten the bolts with a wrench. Do not over tighten, but make sure strong wind and/or rain cannot move the sensor package.

### **4.2.3 Reset Button and Transmitter LED**

In the event the sensor package is not transmitting, reset the sensor.

Using a bent-open paperclip, press and hold the RESET BUTTON (item 12) to affect a reset: the LED turns on while the RESET button is depressed, and you can now let go. The LED should then resume as normal, flashing approximately once every 4.8 seconds.

### **4.3 Rain Gauge Sensor Set Up and Installation**

See Figure 13 to locate and understand all the parts of the rain gauge sensor once fully assembled.

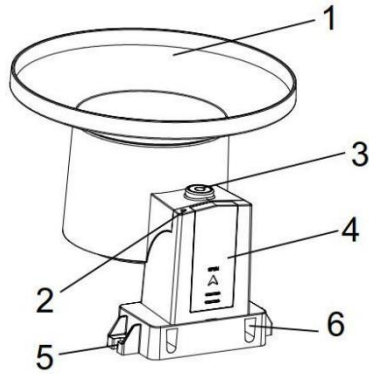

**Figure 13: Sensor assembly components**

1	Rain collector funnel	4	Battery compartment door
2	LED Indicator	5	Surface installation screw hole
3	Bubble level	6	U-bolt installation hole

**Table 3: Sensor assembly detailed items**

#### 4.3.1 Install rain gauge filter

There's a stainless steel filter included in the package. It's aimed to stop leaves or bird's dropping to avoid the obstruction of the cone hole. The installation is simple: press the filter until the hook is inside the outlet hole and self -locked. The spring tension will keep the filter sit tight on the funnel.

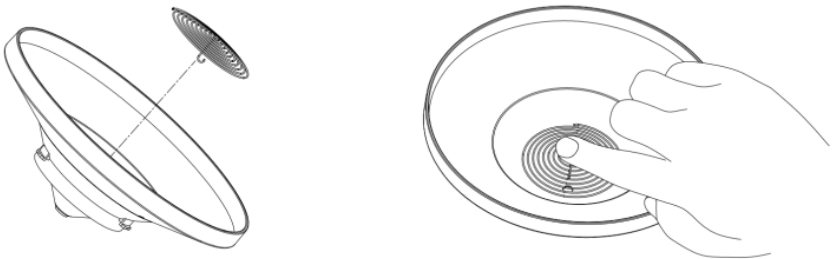

Hook the filter hook on the edge to install.

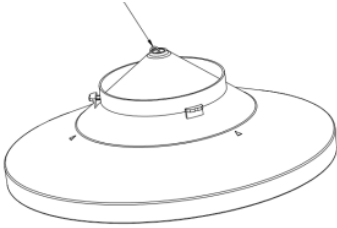

Take out the filter hook from the edge to un-install.

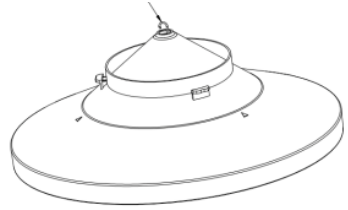

**Figure 14: Rain gauge filter in/un-installation diagram**

### 4.3.2 Install rain collector top

Align the rain collector top with the rain bucket, pay attention to the lock groove position as shown on the left side in Figure 13. Next, lock the top clockwise to the lock groove position, as shown on the right side of the figure, until it comes to a stop and the top cannot be removed from the bucket. Failure to do this may cause the collector top to blow away in strong winds!

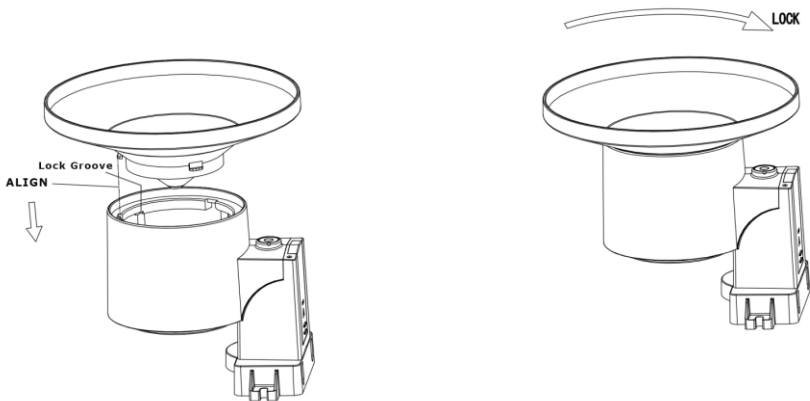

**Figure 15: Rain collector top installation diagram**

### 4.3.3 Install Batteries in rain gauge sensor

Remove the battery door on the back of the sensor by sliding it in the direction of the arrow. Insert one AA battery as described and put compartment door back and slide it in the opposite direction to lock. **Make sure battery door is firmly press and closed properly, which is extremely important in preventing any water entering inside.**



**Figure 16: Rain gauge sensor battery installation diagram**

The LED indicator on the top of the battery door (item 2) will turn on for 4 seconds and then flash once every 49 seconds indicating sensor data transmission. If you did not pay attention, you may have missed the initial indication. You can always remove the batteries and start over, but if you see the flash once every 49 seconds, everything should be OK.

**Note:** If no LED light up or is lighted permanently, make sure the battery is inserted the correct way or a proper reset is happened. Do not install the battery backwards. You can permanently damage the outdoor sensor.

We recommend lithium batteries for cold weather climates, but alkaline batteries are sufficient for most climates.

### 4.3.4 Mounting

#### 4.3.4.1 Before you mount

Before proceeding with the outdoor mounting detailed in this section, you may want to skip to setup instructions in section 4.5 and onwards first, while



you keep the assembled rain gauge sensor nearby (although preferably not closer than 5 ft. from the gateway). This will make any troubleshooting and adjustments easier and avoids any distance or interference related issues from the setup.

After setup is complete and everything is working, return here for outdoor mounting. If issues show up after outdoor mounting they are almost certainly related to distance, obstacles etc.

#### 4.3.4.2 Mounting with U-bolts

The mounting assembly includes two U-Bolts and a bracket that tightens around a 1-2" diameter pole (not included) using the four U-Bolt and nuts.

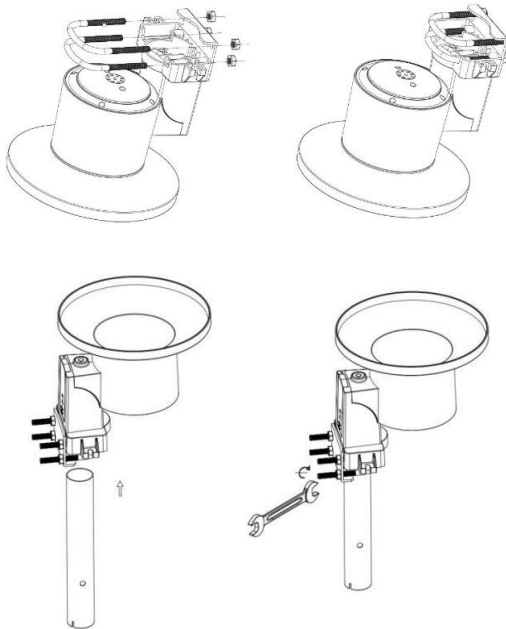
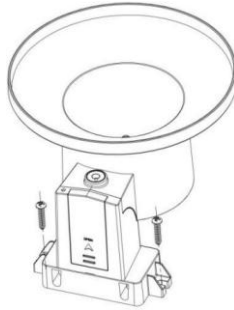

**Figure 17: Rain gauge installation with U-bolts**

**Note:** Use the bubble level on the side of the rain gauge as a guide to verify that the sensor is leveled (for proper measurements).

#### 4.3.4.3 Mounting with screws

The mounting assembly also includes two screws for installation on a flat surface.



**Figure 18: Rain gauge sensor mounting with screws installation diagram**

**Note:** Use the bubble level beside the rain sensor as a guide to verify that the sensor is leveled. Use shims as necessary to achieve level installation.

### 4.4 Indoor Sensor Set Up

**Note:** To avoid permanent damage, please take note of the battery polarity before inserting the batteries. Looking at Figure 4 from left to right the left-most (or bottom) battery is to be installed with its + terminal pointing down, and the other battery with its + terminal pointing up.

Remove the battery door on the back of the sensor by sliding it in the direction of the arrow. Insert two AA batteries as described and put compartment door back and slide it in the opposite direction to lock.

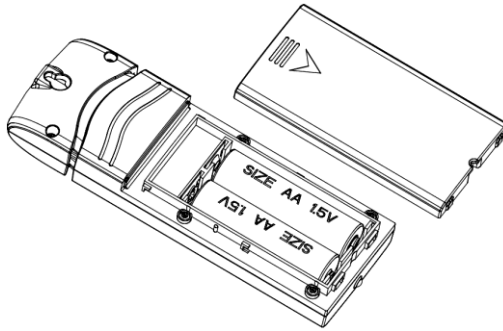

**Figure 4: Indoor sensor battery installation**

#### **4.4.1 Sensor Placement**

The best mounting location for the indoor sensor is in a location that never receives direct sunlight, not even through windows. Also, do not install in a location where a nearby radiant heat source (radiator, heaters, etc.) will affect it. Direct sunlight and radiant heat sources will result in inaccurate temperature readings.

The sensor is meant to provide indoor conditions for display on the console, but if you would rather have a second source for outdoor conditions instead, you can mount this unit outside. The unit is weatherproof, but besides

heeding the placement instructions above, you should also attempt to mount the unit under cover (eave or awning or similar).

To mount or hang the unit on a wall or wood beam:

- Use a screw or nail to affix the remote sensor to the wall, as shown on the left side of Figure , or
- Hang the remote sensor using a string, as shown in right side of Figure

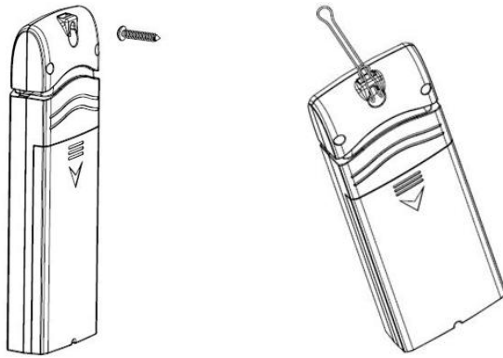

**Figure 20: Indoor sensor mounting**

**Note:** Make sure the sensor is mounted vertically and not lying down on a flat surface. This will insure optimum reception. Wireless signals are impacted by distance, interference (other weather stations, wireless phones, wireless routers, TVs and computer monitors), and transmission barriers, such as walls. In general, wireless signals will not penetrate solid metal and earth (down a hill, for example).

## **4.5 Best Practices for Wireless Communication**

Wireless (RF) communication is susceptible to interference, distance, walls and metal barriers. We recommend the following best practices for trouble free wireless communication between both sensor packages and the base unit:

- **Indoor/outdoor sensor placement:** The sensor will have the longest reach for its signal when mounted or hung vertically. Avoid laying it down on a flat surface.
- **Electro-Magnetic Interference (EMI).** Keep the base unit several feet away from computer monitors and TVs.
- **Radio Frequency Interference (RFI).** If you have other devices operating on the same frequency band as your indoor and/or outdoor sensors and experience intermittent communication between sensor package and base unit, try turning off these other devices for

troubleshooting purposes. You may need to relocate the transmitters or receivers to avoid the interference and establish reliable communication. The frequencies used by the sensors are one of (depending on your location): 433, 868, or 915 MHz (915 MHz for United States, 868 MHz for European, 433 MHz for other area).

- **Line of Sight Rating.** This device is rated at 300 feet line of sight (under ideal circumstances; no interference, barriers or walls), but in most real-world scenarios, including a wall or two, you will be able to go about 100 feet.
- **Metal Barriers.** Radio frequency will not pass through metal barriers such as aluminum siding or metal wall framing. If you have such metal barriers and experience communication problems, you must change the placement of sensor package and or base unit.

The following table shows different transmission media and expected signal strength reductions. Each “wall” or obstruction decreases the transmission range by the factor shown below.

Medium	RF Signal Strength Reduction
Glass (untreated)	5-15%
Plastics	10-15%
Wood	10-40%
Brick	10-40%
Concrete	40-80%
Metal	90-100%

**Table 4: RF Signal Strength reduction**

### 4.6 Console Display

See Figure to help you identify elements of the console’s display screen.

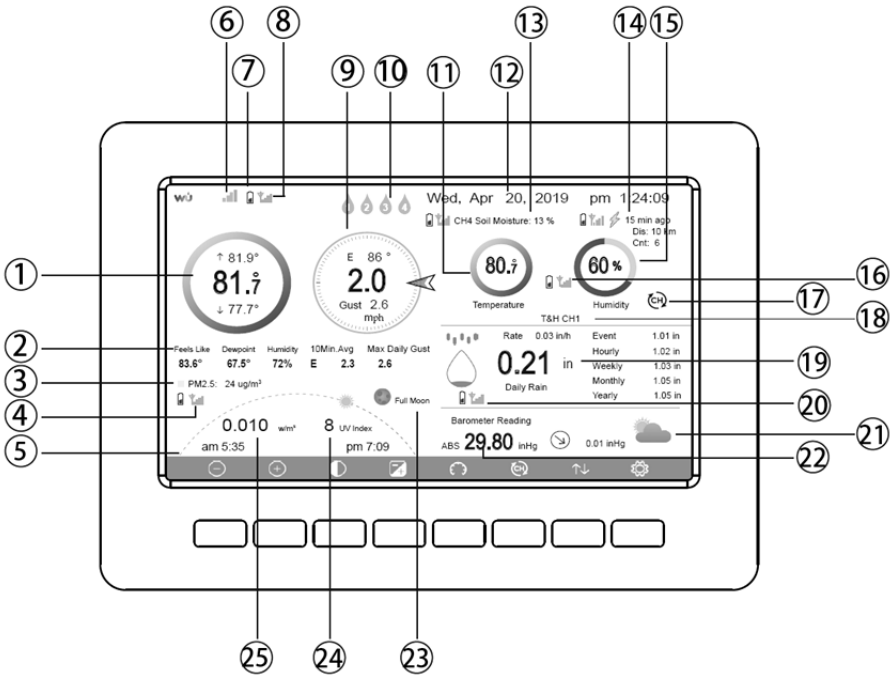

**Figure 21: Display Console Screen Layout**

No	Description	No	Description
1	Outdoor temperature	14	Last lightning strikes detected time / distance; daily counts (optional sensor)
2	Outdoor Feels Like/Dew point/Humidity/10Min. Average Wind Direction/Max Daily Gust	15	Indoor humidity
3	PM2.5 concentration display, WH41/WH43/WH45 particle detection sensor cycle display(optional sensor)	16	RF signal bar for multi-channel temperature and humidity sensor(optional sensor)

No	Description	No	Description
4	RF signal bar for PM2.5 sensor(optional sensor)	17	Multi-channel temperature and humidity sensor cycle display mode icon(optional sensor)
5	Sunrise / Sunset Time	18	Multi-channel temperature and humidity sensor channel number (optional sensor)
6	Wi-Fi signal bar	19	Rain fall Daily/Event/Hourly/Weekly/ Monthly/Yearly
7	Low battery power indicator for each sensor	20	RF signal bar for rain fall sensor
8	RF signal bar for outdoor sensor array	21	Weather forecast
9	Wind direction/Wind speed/Gust	22	ABS/REL Barometer
10	Multi-channel water leak sensor (optional)	23	Moon Phase
11	Indoor temperature	24	UV
12	Date and time	25	Solar Radiation
13	Soil moisture(optional sensor)		

**Table: Display console detailed items**

**Note:** If you have purchased the optional WH55 water leak sensor, please check the following instructions for the display color:

- Green - normal
- Red & Flash - leaking
- Yellow - low battery alert
- Orange - offline over 10 minutes

## 4.6.1 Initial Display Console Set Up

Immediately after power up (inserting power adapter), the unit will turn on the display, and the unit will start to look for reception of the indoor and outdoor sensor data. This may take up to 3 minutes.



**Dark Background Display**



**Light Background Display**

**Note:** Sunrise/sunset time display will only work properly when GEO location has been set up correctly. GEO setup can be carried out under setup menu.





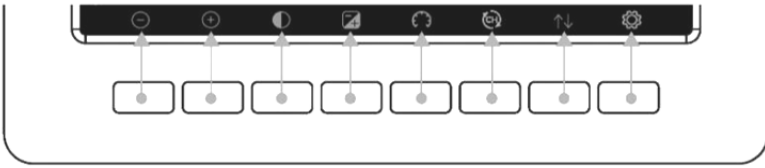





## 4.6.2 Key functions



**Figure: Buttons around the display**













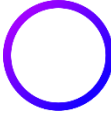

There is a set of eight keys on the bottom of the display console. The following tables briefly explains the function of these keys.

Icon	Description
	<b>Brightness control key</b> Press this key to decrease the brightness
	<b>Brightness control key</b> Press this key to enhance the brightness
	<b>Backlight on/off key</b> Press this key to on/off the backlight
	<b>Background key</b> Press this key to choose between dark background display and light background display
	<b>Pressure display key</b> Press this key to choose the display between Absolute pressure and Relative pressure.
	<b>Channel key</b> Press this key to Shift the display between indoor temp & humidity, Multiple Channel temp& humidity and scroll automatically mode
	<b>History key</b> Press this key once to view Max/Min record; Press twice to enter History mode; Press three times to enter Graph Mode; Press four times to enter optional Sensors Display Mode
	<b>Setting key</b> Press this key to enter Setting Mode

**Table: Console buttons**













## 4.6.3 Main interface icons explain



### 4.6.3.1 Temperature Icon

Temperature Range (degF)	Color Ring	Temperature Range (degF)	Color Ring
< -10		50-60	
-10 to 0		60-70	
0 to 10		70-80	
10-20		80-90	
20-30		90-100	
30-40		100-110	
40-50		> 110	









**Note:** please refer to the online manual for colorful display.

### 4.6.3.2 Humidity Icon

Humidity Range (%)	Color Ring	Humidity Range (%)	Color Ring
0%, No signal or dashes		50 to 60	
1 to 10		60 to 70	
10 to 20		70 to 80	
20 to 30		80 to 90	
30 to 40		90 to 99	
40 to 50		100%	

**4.6.3.3 Current wind direction indication  , 10-minute average wind direction indication  .**

**4.6.3.4 Hourly Rainfall Icon**

Hourly Rain (in)	Icon	Hourly Rain (in)	Color Ring
0.0		0.6 to 0.8	
0 to 0.2		0.8 to 1	
0.2 to 0.4		1 to 1.2	
0.4 to 0.6		1.2 to 1.4	

**4.7 Multiple Channel Selection and Scroll Mode**

The multi-channel sensor is an optional sensor, not included in the package.

If you have multiple wireless sensors, while in normal mode, press the  key to toggle display in sequence of indoor, ch1, ch2....ch8, scroll display. Please note if only CH2 is received, it will skip CH1, and toggle only between indoor and already learned sensors.

While in Scroll display mode, the scroll icon  will be displayed next to the indoor humidity, and will scroll every 5 seconds.

**Note:** For all optional sensor(s), the history data will be saved to a microSD card(not included).

## 4.8 History Mode

### 4.8.1 View and Reset MAX/MIN

While in normal display, press the  key once to view and reset minimum and maximums.

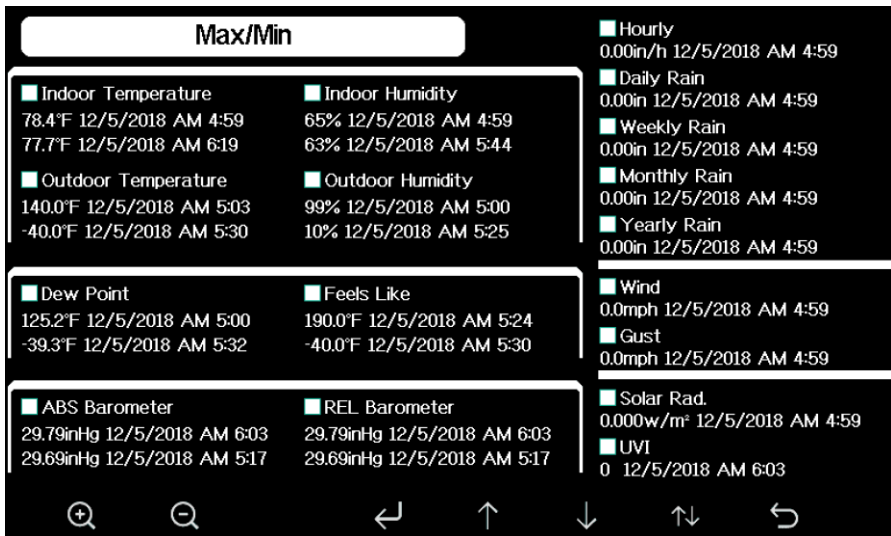













Figure: Max/Min Screen









Icon	Description
	<p><b>Selection key</b></p> <p>Press this key to select the weather MAX/MIN record which need to clear</p>
	<p><b>Selection key</b></p> <p>Press this key to select the weather MAX/MIN record which need to clear</p>
	<p><b>Enter key</b></p> <p>While the desired weather MAX/MIN record selected , press this key to popup Message Box ”Clear the Max/Min record?”. Press  key or  key to select YES or NO. Press the  key or  key to confirm the selection.</p>
	<p><b>Up arrow key</b></p> <p>Press this key to change the activated option field</p>
	<p><b>Down arrow key</b></p> <p>Press this key to change the activated option field</p>
	<p><b>History key</b></p> <p>Press this key to select History data display.</p>
	<p><b>Return key</b></p> <p>Press this key to return to normal display mode</p>

## 4.8.2 History Record Mode

While in normal display, press the  key twice to enter History Record Mode.

No	Time	Indoor Temperature (°F)	Indoor Humidity (%)	Outdoor Temperature (°F)	Outdoor Humidity (%)	Dew Point (°F)	Feels Like (°F)	Wind (mph)
2689	12/5/2018 AM 6:40	77.7	65	68.9	47	47.8	68.9	2.5
2690	12/5/2018 AM 6:45	77.7	65	68.9	47	47.8	68.9	2.5
2691	12/5/2018 AM 6:50	77.7	65	68.9	47	47.8	68.9	2.2
2692	12/5/2018 AM 2:40	77.9	65	68.9	47	47.8	68.9	2.5
2693	12/5/2018 AM 2:45	77.9	65	68.9	47	47.8	68.9	2.2
2694	12/5/2018 AM 2:50	77.9	65	68.9	47	47.8	68.9	2.2
2695	12/5/2018 AM 2:55	77.9	65	68.9	46	47.3	68.9	2.2
2696	12/5/2018 AM 3:00	77.9	65	68.9	46	47.3	68.9	2.2
2697	12/5/2018 AM 3:05	77.9	65	68.9	46	47.3	68.9	2.2
2698	12/5/2018 AM 3:10	77.9	65	68.9	46	47.3	68.9	2.2
2699	12/5/2018 AM 3:15	77.9	65	68.9	46	47.3	68.9	2.7
2700	12/5/2018 AM 3:20	77.9	64	68.9	46	47.3	68.9	2.5
2701	12/5/2018 AM 3:25	77.9	65	68.9	46	47.3	68.9	2.2
2702	12/5/2018 AM 3:30	78.1	65	68.9	46	47.3	68.9	2.2
2703	12/5/2018 AM 3:35	78.6	65	68.9	46	47.3	68.9	2.2
2704	12/5/2018 AM 3:40	78.6	65	68.9	46	47.3	68.9	2.2

**Figure : History record Screen**

Icon	Description
	<b>File Select key</b> Press this key to clear all history record
	<b>Page Select key</b> Press this key to enter particular page of the history data. Each page contains 16sets data.
	<b>Scroll left key</b> Press this key to view the left of the scrollable area.
	<b>Scroll right key</b> Press this key to view the right of the scrollable area.
	<b>Page up key</b> Press this key to scroll up the page you are viewing
	<b>Page down key</b> Press this key to scroll down the page you are viewing
	<b>History key</b> Press this key to select the Max/Min record or History.
	<b>Return key</b> Press this key to return to previous mode













No	Time	Indoor Temperature (°F)	Indoor Humidity (%)	Outdoor Temperature (°F)	Outdoor Humidity (%)	Dew Point (°F)	Feels Like (°F)	Wind (mph)
2721	12/5/2018 AM 5:13	78.4	65	24.8	54	10.4	24.8	0.0
2722	12/5/2018 AM 5:18	78.4	65	59.0	73	50.4	59.0	0.0
2723	12/5/2018 AM 5:23	78.4	65	87.8	89	84.2	111.7	0.0
2724	12/5/2018 AM 5:28	78.4	65	123.8	19	69.8	123.8	0.0
2725	12/5/2018 AM 5:33				89	-39.3	-22.0	0.0
2726	12/5/2018 AM 5:38				58	0.1	12.2	0.0
2727	12/5/2018 AM 5:43				74	33.4	41.0	0.0
2728	12/5/2018 AM 5:48				95	77.2	78.8	0.0
2729	12/5/2018 AM 5:52				84	67.6	113.0	0.0
2730	12/5/2018 AM 5:57				42	--	-36.4	0.0
2731	12/5/2018 AM 6:24	77.4	64	-4.0	71	-11.2	-4.0	0.0

View data on page 1 to 171

00171

Ok
Cancel



**Figure : view a specific page of history Screen**

Press  or  to select a digit in a number, press  or  key to change the number. Press  or  to change the activated option field, toggle OK or Cancel then press  or  key to confirm.

### 4.8.3 Graph Mode

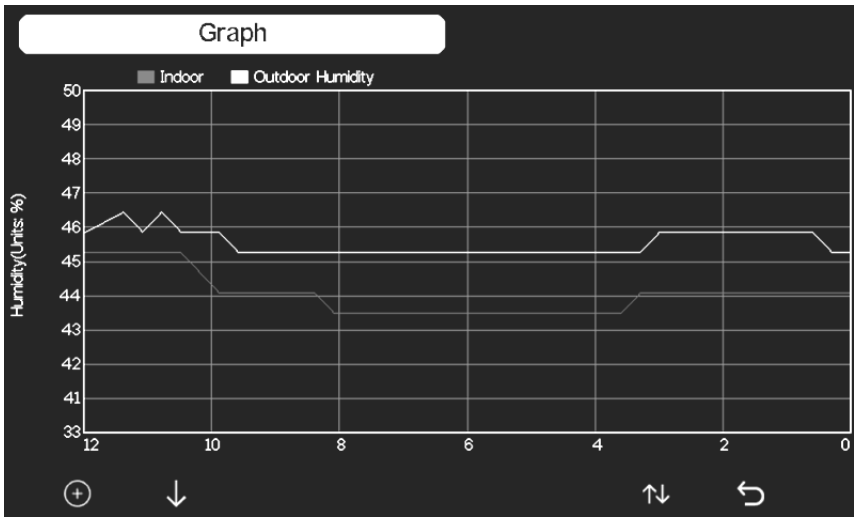
While in History Record Mode, press the  key once to enter Graph Mode.



Press  to shift the data display of 12/24/48/72H. Press  to view the graph of the following data:

- Indoor outdoor humidity
- Dew Point and Feels like
- Indoor outdoor temperature
- Wind speed and Gust
- Wind Direction
- UVI
- Solar radiation
- Rainfall hourly and daily
- Barometer(REL & ABS)

## 4.8.4 Optional Sensor Display Mode

To view the full display of multi-channel sensors you can do this:



While in Graph Mode, press the  key once to enter Optional Sensor Display Mode.

CH1 27.1°C 67%	CH2 27.2°C 67%	CH3 27.3°C 66%	CH4 27.3°C 66%	CH5 27.1°C 67%	CH6 27.4°C 67%	CH7 27.3°C 66%	CH8 27.3°C 66%
Soil CH1 0%	Soil CH2 0%	Soil CH3 0%	Soil CH4 0%	Soil CH5 0%	Soil CH6 0%	Soil CH7 0%	Soil CH8 32%
PM2.5 CH2 29ug/m³ Moderate AQI 87 24H 68	PM2.5 CH3 31ug/m³ Moderate AQI 91 24H 93	Water CH2 Normal	Water CH4 Normal	Lightning 20 min ago Dis 20km Cnt 5			











Note: Channel names can be edited on this page

## 4.9 Setting Mode



While in normal display, press the  key to enter Setting Mode. You can select the below sub-mode by pressing the  key

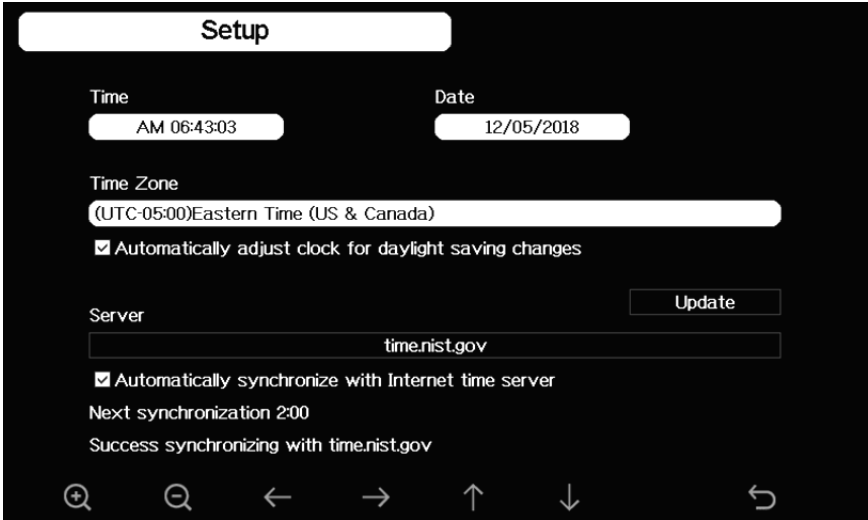

**Figure : Setup Menu Screen**

Icon	Description
	<b>Select key</b> Press this key to select the unit or scrolls the value
	<b>Select key</b> Press this key to select the unit or scrolls the value.
	<b>Left key</b> Press this key to select the set value.
	<b>Right key</b> Press this key to select the set value.
	<b>Up arrow key</b> Press this key to change the activated option field
	<b>Down arrow key</b> Press this key to change the activated option field
	<b>Set key</b> Press this key to select the Setting sub-Mode
	<b>Return key</b> Press this key to return to previous mode









## 4.9.1 Date and Time setting

While in Menu Setting Mode, press  key to select Date and Time Setup field, press  or  key to enter Date and Time Setup mode:











**Figure : Time and date Setup Screen**







### 1) Time setting (hour/minute/second)

Press  key to select time setting field, and the hour digit will turn red, press the  or  key to change the hour setting. Press  to set the minute, the minute digit will turn red, press the  or  key to change the minute setting. Press  to set the second, and the second digit will turn red, press the  or  key to change the second setting



## 2) Date setting

Press  key to select Date setting field, the day digit on focus turns red, press the  or  key to change the day setting. Press  to set the month, then month digit focused will turn red, press the  or  key to change the month setting. Press  to set the year, the year digit on focus will turn red, press the  or  key to change the year setting

## 3) Time zone setting

Press  key to select Time zone setting field, press the  or  key to change the time zone setting. Press  key to select Update field, press the  or  key to update the time immediately.

## 4) Automatically synchronize with internet time server

The time server is [time.nist.gov](http://time.nist.gov). Press the  or  key to tick "Automatically synchronize with internet time server" and press "update" to synchronize with time server immediately. Console time will be updated at 2:01am automatically when internet access is possible.

## 4.9.2 Time Format setting

Press  to change the time format between hour: minute: second (h:mm:ss), hour: minute: second AM (h:mm:ss AM) and AM hour: minute: second (AM h:mm:ss).

### 4.9.3 Date Format setting

Press  to change the time format between DD-MM-YYYY, YYYY-MM-DD and MM-DD-YYYY

### 4.9.4 Temperature unit setting

Press  to change the temperature units of measure between °F and °C.

### 4.9.5 Barometric unit

Press  to change the temperature units of measure between inHg, mmHg and hPa

### 4.9.6 Wind speed unit

Press  to change the wind speed units of measure between mph, bft (Beaufort scale), ft/s, m/s, km/h and knot.

### 4.9.7 Rainfall unit

Press  to change the rainfall units of measure between in and mm

### 4.9.8 Solar Rad. Unit







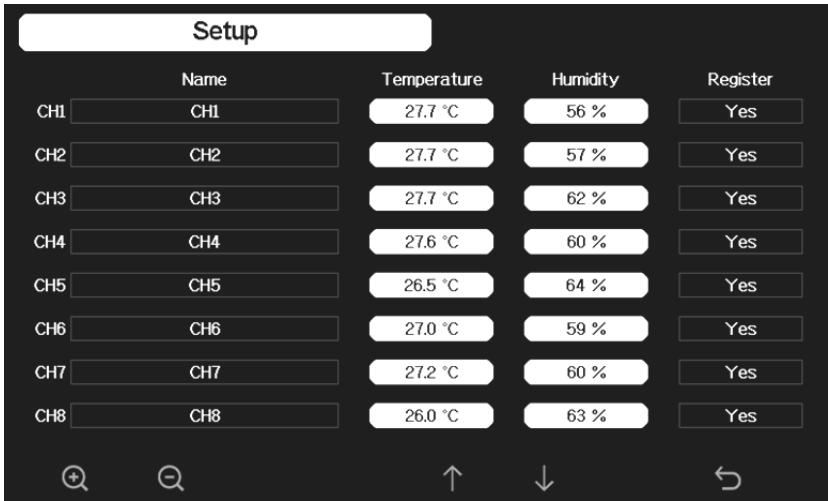



Press  to change the solar radiation units of measure between W/m<sup>2</sup>, lux and fc.

### 4.9.9 Multi Channel Sensor

In Multi channel sensor Setup Screen, you can rename the multi-channel temperature and humidity sensor or register the sensor again while the sensor lost connection to console display.





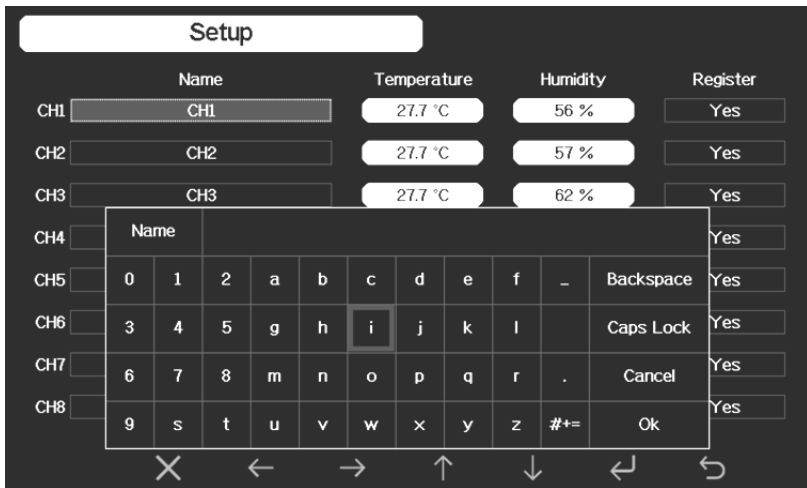

**Figure : Multi channel sensor Setup Screen**

Press  or  key to select Name setting field, the name on focus turns green, press the  or  key to pop up the keyboard to enter the sensor name. Press     to scroll to the character and press  to select the character. Press  to return to the setup page.





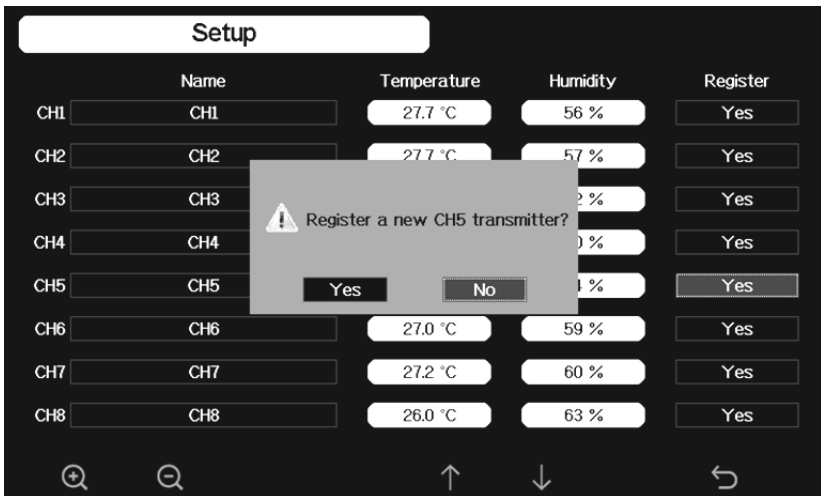

**Figure : rename the sensor Screen**

Press  or  key to select Register setting field, press the  or  key to register the selected sensor



## 4.9.10 Backlight setting

While in Menu Setting Mode, press  key to select Backlight Setup field, press  or  key to enter backlight Setup mode:

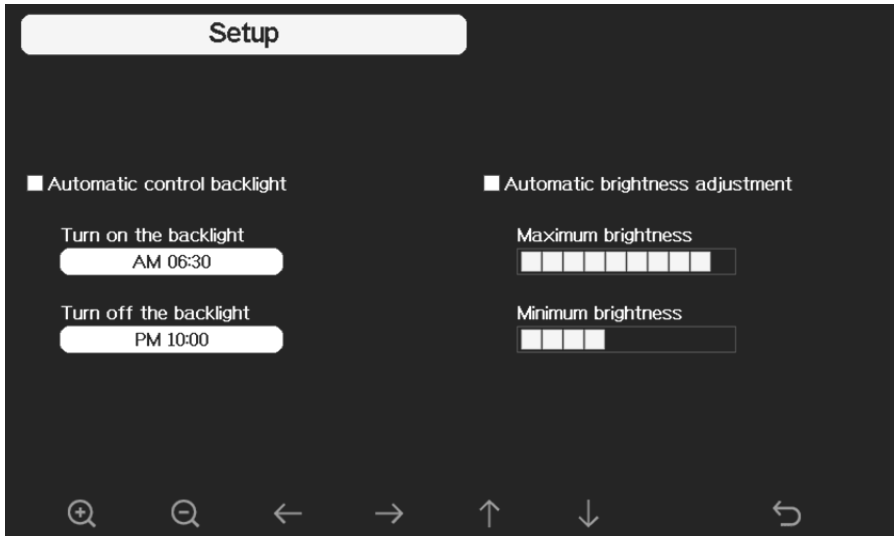

**Figure : Backlight Setting Screen**

Automatic control backlight: select this option, the backlight will auto turn on and off according the set time







Turn on the backlight: set the time of turning on backlight

Turn off the backlight: set the time of turning off backlight

Automatic brightness adjustment: select this option, the brightness will change according to the light intensity measured from outdoor sensor

Maximum brightness: set the maximum brightness while it is the highest light intensity



Minimum brightness: set the minimum brightness while it is the weakest light intensity

Icon	Description
	<b>Select key</b> Press this key to select the unit or scrolls the value
	<b>Select key</b> Press this key to select the unit or scrolls the value.
	<b>Left key</b> Press this key to select the set value.
	<b>Right key</b> Press this key to select the set value.
	<b>Up arrow key</b> Press this key to change the activated option field
	<b>Down arrow key</b> Press this key to change the activated option field
	<b>Return key</b> Press this key to return to previous mode

If the auto backlight turn-on time has been set, you can press  key to turn off the backlight within the turn on time. Backlight will turn on again automatically at next turn on time. You can press any key to turn on the backlight for 60s within the turn off time

#### 4.9.11 Longitude: Latitude setting

While in Menu Setting Mode, press  key to select Longitude: Latitude

Setup field, press  or  key to enter Longitude Latitude Setup mode:



**Figure : Longitude and Latitude Setting Screen**

The sunrise/sunset times will be calculating automatically base on the Longitude and Latitude. Your location GEO info can be found on mobile compass page. Two digits after decimal should be enough for this feature to be working correctly.

#### **4.9.12 Week Start Set**

Press  to set the week start at Sunday or Monday.

#### **4.9.13 Rainfall season (default: January)**

Press  to change the beginning of the rainfall yearly season month. The default is January. Rainfall season influence the annual rainfall maximum, minimum and total value. When one month was selected, the annual rainfall and annual max/min rainfall were zero clearing at 0:00 of the first day of the selected month.

## 4.9.14 Storing Interval (1-240minutes Selectable)

## 4.9.15 Weather Server

You may jump to section 4.9.16 now to have your console connected with your Wi-Fi network first. Then back to this section to have cloud data hosting setup completed.



Your console is capable of sending your sensor data to select internet-based weather services. The supported services are shown in the table below:

Service	Description
Weather Underground	Site: <a href="https://wunderground.com">https://wunderground.com</a> provides local & long-range weather forecasts, weather reports, maps & tropical weather conditions for locations worldwide.
WOW	Site: <a href="https://wow.metoffice.gov.uk">https://wow.metoffice.gov.uk</a> A UK based weather observation website.
Weather Cloud	Site: <a href="https://weathercloud.net">https://weathercloud.net</a> A large network of weather stations reporting data in real time from all over the world.
Ecowitt Weather	Site: <a href="https://www.ecowitt.net">https://www.ecowitt.net</a> Ecowitt's new weather server that can host a bunch of sensors that other services don't support at this time.

**Table: Supported weather services**



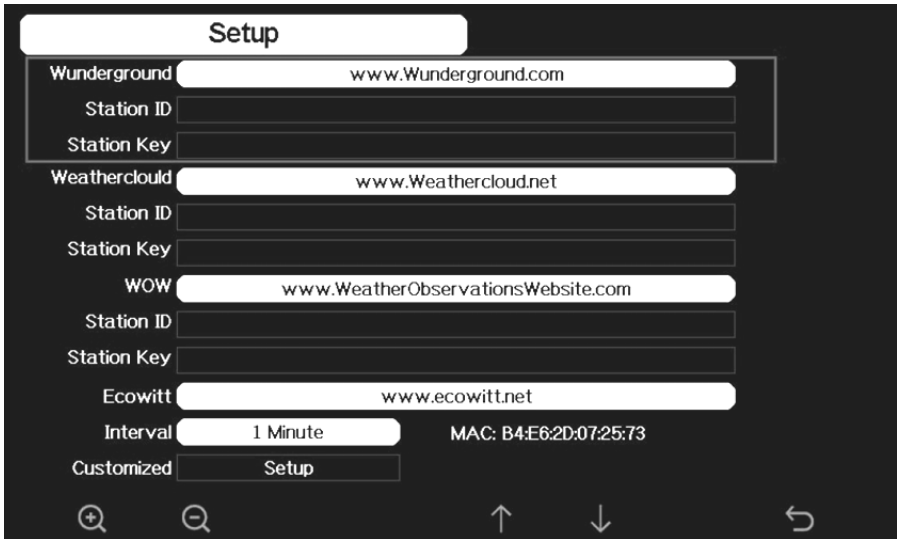

**Note:** If you are testing the setup with the outdoor sensor package nearby and indoor, you may want to consider connecting to Wi-Fi, but not yet configuring any of the weather services. The reason is that while indoor the temperatures and humidity recorded by the outdoor sensor, and as reported to the weather service(s) will reflect indoor conditions, and not outdoor conditions. Therefore, they will be incorrect. Furthermore, the rainfall bucket may be tripped during handling, causing rain to register while it may not actually have been raining. One way to prevent this is to follow all instructions, except to use an incorrect password, on purpose! Then, after

final outdoor installation, come back and change the password after clearing console history. That will start uploading to the services with a clean slate.

Press  or  key to enter Weather Server set up mode. The device can be configured to send real-time data to wunderground.com®. Enter the Station ID and Password obtained from Wunderground.com.



**Figure : Weather Server setup screen**

				
scroll value up	scroll value down	Scroll field up	Scroll field down	return to Setup



- 1) **Set Station ID.** Press to highlight the Station ID. Enter your station ID. Press to display the keyboard. Press to scroll to the character and press to select the character. Press the “OK” button to confirm. Press to return to the setup page.
- 2) **Set Station Key.** Press to highlight the station key. Enter your password obtained from according weather server. Press to display the keyboard. Press to scroll to the character and press to select the character. Press the “OK” button to confirm. Press to return to the setup page.

## 4.9.15.1 Registering with and using wunderground.com

Perform the following steps to get the Station ID and Password on wunderground.com:

1. Visit Wunderground.com and select the **Join** link at the top of the page and sign up.

WEATHER UNDERGROUND | Sensor Network | Maps & Radar | Severe Weather | News & Blogs | Mobile Apps | More | Search Locations | Log in | Join

Popular Cities: San Francisco, CA (53°F Clear), Manhattan, NY (51°F Clear), Schiller Park, IL (60176) (41°F Mostly Cloudy), Boston, MA (54°F Cloudy), Houston, TX (79°F Cloudy), London, England, United Kingdom (WC2H TDE) (51°F Mostly Cloudy)

### Member Account

### Join Weather Underground

- Choose real-time alerts for your city.
- Choose adding your webcam or personal weather station.
- You can delete your account at any time from your member settings.

The Weather Company needs your email to create your Weather Underground account.

Email:

Password (5-30 characters) [Show](#):

Confirm New Password:

I agree to the [Terms of Use](#)

[Sign up for free](#)

Already have an account? [Sign in](#)

2. Click **My Profile** and select **My Devices** to register your station

WEATHER UNDERGROUND | Sensor Network | Maps & Radar | Severe Weather | News & Blogs | Mobile Apps | More | Search Locations | My Profile | Welcome back!

Popular Cities: 53°F San Francisco, CA, 51°F Manhattan, NY, 40°F Schiller Park, IL (60176), 54°F Boston, MA, 79°F Houston, TX, 52°F London, England

### San Francisco, CA

50°F | 48° | 4% / 0.00 in

Feels like 47°

12AM 3AM NOON 6PM 12AM

50° 49° 49° 59° 63° 62° 50° 51° 44°

May 11 May 12

[Full Forecast](#)

[Member Settings](#)

[My Devices](#)

[Sign Out](#)



### 3. Select Add New Device.

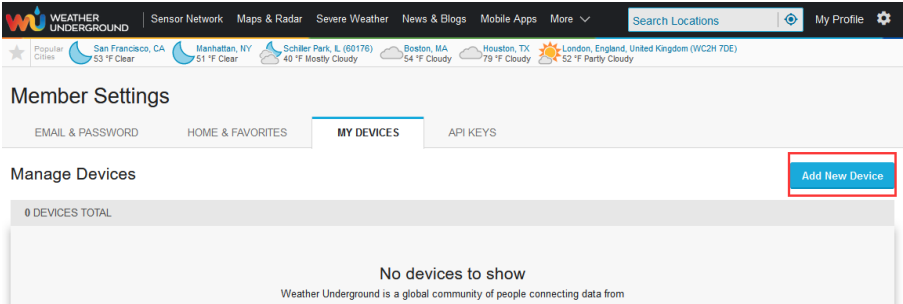

WEATHER UNDERGROUND | Sensor Network | Maps & Radar | Severe Weather | News & Blogs | Mobile Apps | More | Search Locations | My Profile

Popular Cities: San Francisco, CA (53°F Clear), Manhattan, NY (51°F Clear), Schiller Park, IL (60176) (40°F Mostly Cloudy), Boston, MA (54°F Cloudy), Houston, TX (79°F Cloudy), London, England, United Kingdom (WC2H 7DE) (52°F Partly Cloudy)

### Member Settings

EMAIL & PASSWORD | HOME & FAVORITES | **MY DEVICES** | API KEYS

### Manage Devices

0 DEVICES TOTAL

No devices to show  
Weather Underground is a global community of people connecting data from

**Add New Device**

### 4. Find Personal Weather Station. Select 'other' and click 'Next'.

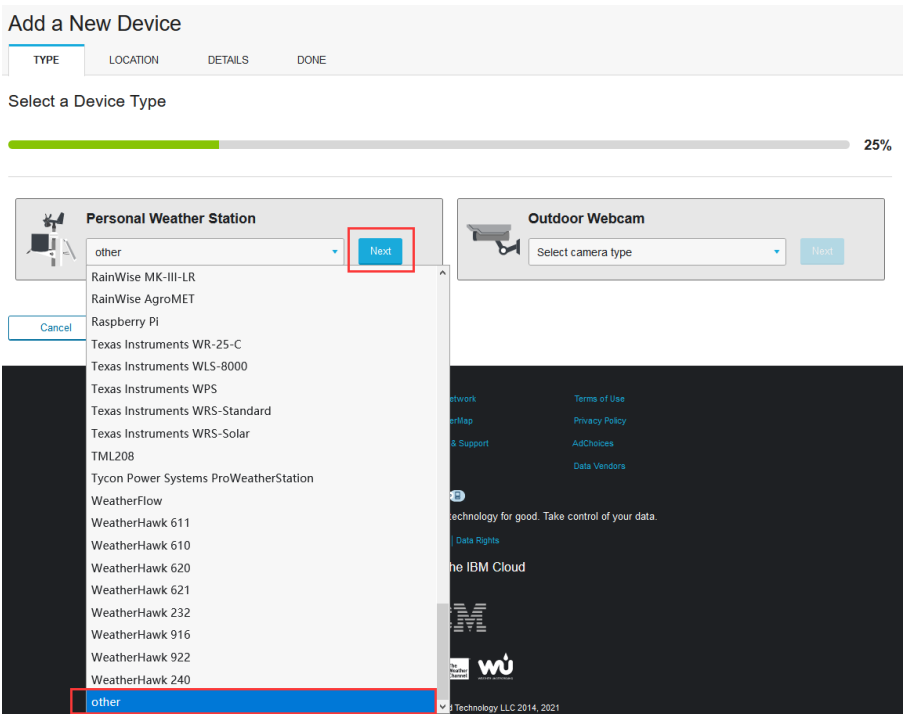

### Add a New Device

TYPE | LOCATION | DETAILS | DONE

### Select a Device Type

25%

#### Personal Weather Station

other | **Next**

- RainWise MK-III-LR
- RainWise AgroMET
- Raspberry Pi
- Texas Instruments WR-25-C
- Texas Instruments WLS-8000
- Texas Instruments WPS
- Texas Instruments WRS-Standard
- Texas Instruments WRS-Solar
- TML208
- Tycon Power Systems ProWeatherStation
- WeatherFlow
- WeatherHawk 611
- WeatherHawk 610
- WeatherHawk 620
- WeatherHawk 621
- WeatherHawk 232
- WeatherHawk 916
- WeatherHawk 922
- WeatherHawk 240
- other**

Cancel

#### Outdoor Webcam

Select camera type | Next

Technology LLC 2014, 2021

5. Select 'Address' or 'Manual' option, and find your local position. Press 'Next'.

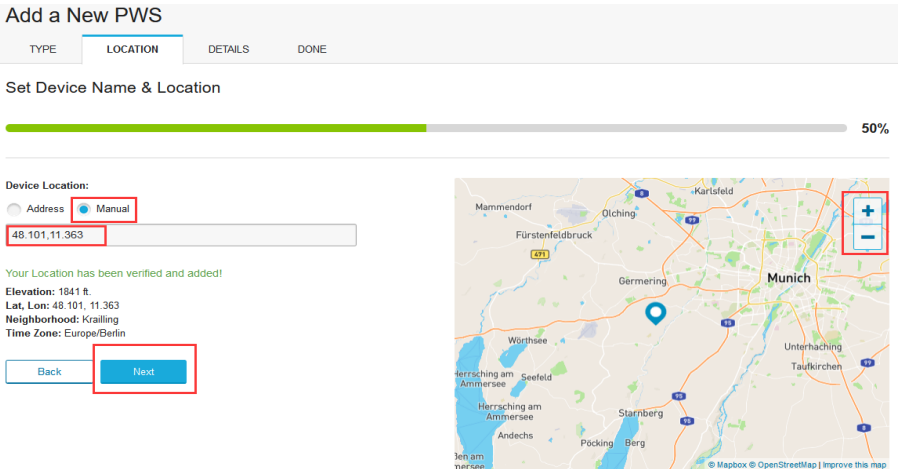

6. This time you will be asked details about your weather station. Go ahead and fill out the form.

## Add a New PWS

TYPE LOCATION **DETAILS** DONE

### Tell Us More About Your Device

75%

Name:(Required)

Surface Type:

Elevation:(Required)

Associate Webcam:

Device Hardware:(Required)

Height Above Ground:

#### You Make Our Forecasts More Accurate, We Respect Your Privacy

Contribute to the Weather Underground community by sharing some information about yourself and your sensor. We use this information to manage your account and to improve the experience from the Weather Underground community. We may also share certain data for commercial purposes, such as your sensor location.

[Learn more about how we take your privacy seriously](#)

(Required)

I Accept  I Deny

Email Preferences:

I would like to receive PWS notifications.

- After completing the weather station, you will see station ID and key/password.

## Add a New PWS

TYPE LOCATION DETAILS **DONE**

### Registration Complete!

100%

Congratulations! Your personal weather station is now registered with Weather Underground.

Enter the information below to your weather station software.

Your PWS

Station ID:





Station Key:

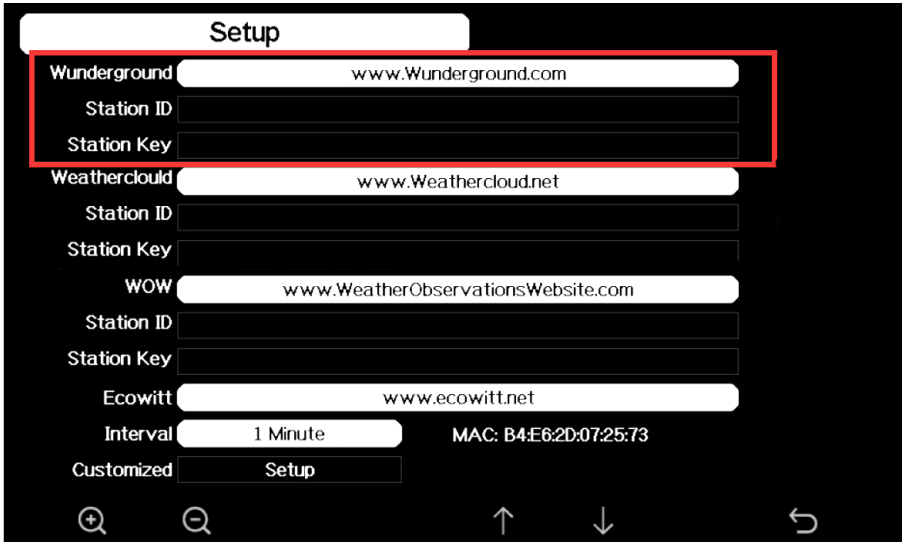

- Take note of the station ID and key/password and enter it in the Weather Server:



**Figure 31: Weather Server setup screen**

				
scroll value up	scroll value down	Scroll field up	Scroll field down	return to Setup



1) **Set Station ID.** Press to highlight the Station ID. Enter your station ID. Press to display the keyboard. Press to scroll to the character and press to select the character. Press the “OK” button to confirm. Press to return to the setup page.

2) **Set Station Key.** Press to highlight the station key. Enter your password obtained from according weather server. Press to display the keyboard. Press to scroll to the character and press to select the character. Press the “OK” button to confirm. Press to return to the setup page.

9. Refresh the page, you may have to wait about a few minutes until the status becomes 'Online'. Then you can click device name to view data.

Member Settings

EMAIL & PASSWORD   HOME & FAVORITES   **MY DEVICES**   API KEYS

Manage Devices Add New Device

1 DEVICES TOTAL

Name	Location	Status	ID	Key	Type	Manage
<b>HP2251-1</b>	Shenzhen (Nanshan District), CN	<b>Online</b>			PWS	Edit   Delete   Copy credentials

Items per page: 10   1 – 1 of 1

### 4.9.15.2 Viewing data on wunderground.com

The most basic way to observe your weather station's data is by using the wunderground.com web site. You will use a URL like this one, where your station ID replaces the text "STATIONID":

<http://www.wunderground.com/personal-weather-station/dashboard?ID=STATIONID>

It will show a page such as this, where you can look at today's data and historical data as well:

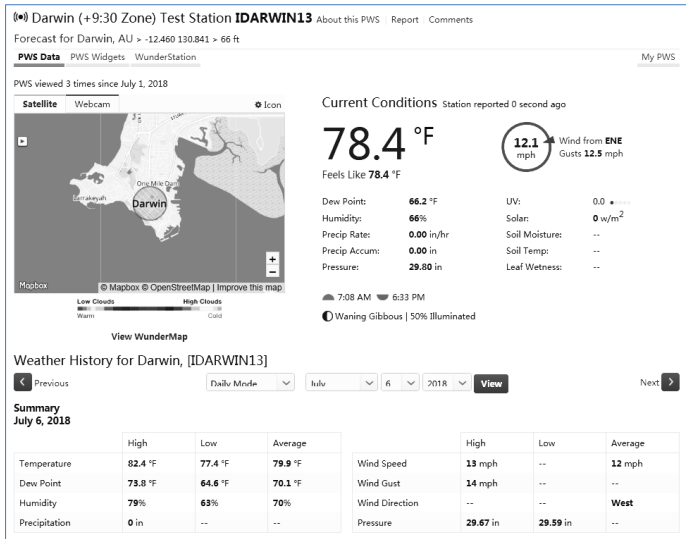

There are also some very useful mobile apps. The URLs provided here go to the Web version of the application pages. You can also find them directly from the iOS or Google Play stores:

- WunderStation:** iPad application for viewing your station's data and graphs  
<https://itunes.apple.com/us/app/wunderstation-weather-from-your-neighborhood/id906099986>

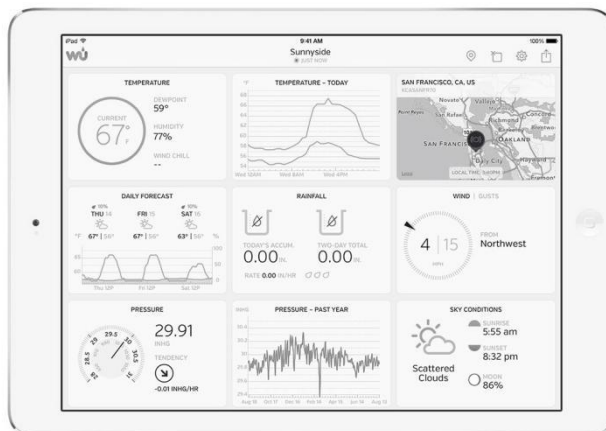

- **WU Storm:** iPad and iPhone application for viewing radar images, animated wind, cloud coverage and detailed forecast, and PWS station data

<https://itunes.apple.com/us/app/wu-storm/id955957721>

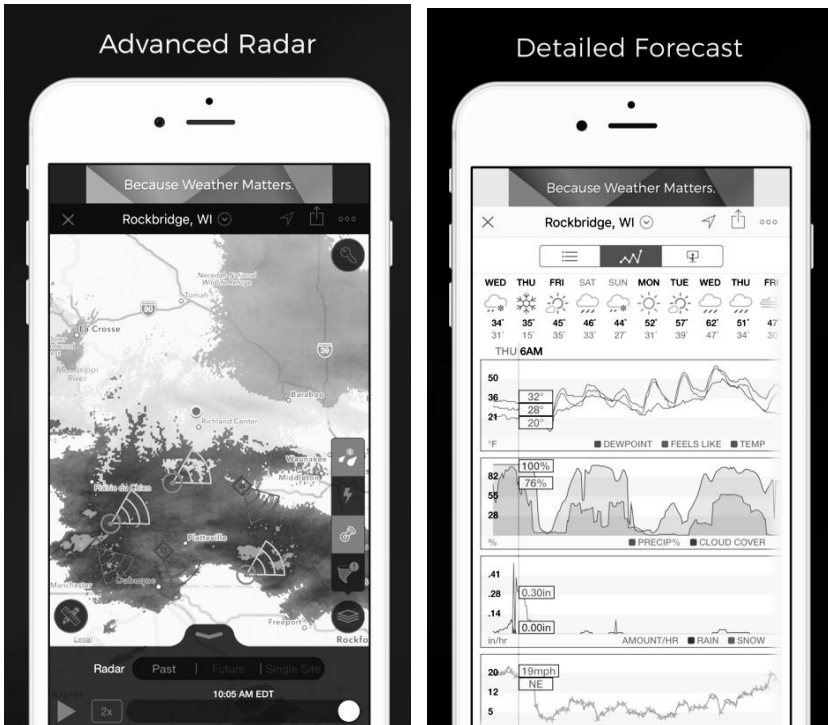

- **Weather Underground: Forecast:** iOS and Android application for forecasts

<https://itunes.apple.com/us/app/weather-underground-forecast/id486154808>

<https://play.google.com/store/apps/details?id=com.wunderground.android.weather&hl=en>





**PWS Weather Station Monitor:** View weather conditions in your neighborhood, or even right in your own backyard. Connects to wunderground.com

<https://itunes.apple.com/us/app/pws-weather-station-monitor/id713705929>

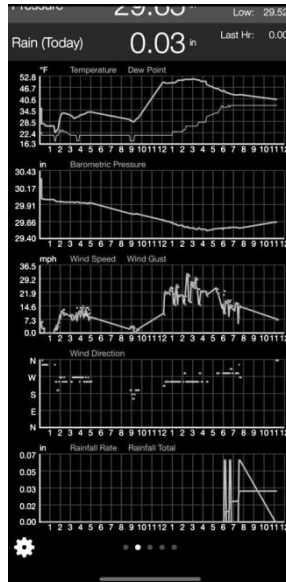

### 4.9.15.3 Registering with and using Ecowitt Weather

You can also use the Ecowitt Weather server to monitor and record all your sensors' data. Configure as follows:

- On the Weather Server page, set the reporting interval time(default: 1 minute).
- Visit the website: <https://www.ecowitt.net> on your computer and finish the registration on the page.
  - Press the upper left menu button and select Devices.
  - Press Add Device and input all the information needed(The MAC address can be found on the Weather Server page).
  - Press Save.
  - Press Dashboard on the menu. Your sensor data would be available on the dashboard within several minutes.

**Note:** When select device address on map, please wait until the map displays before selecting your address.

You may add a shortcut to the ecowitt.net website on the home page of your phone so that you can visit it just like opening an app.

### 4.9.15.4 Viewing data on ecowitt.net

You can observe your sensor's data by using the ecowitt.net web site. You will use a URL like this one, where your station ID replaces the text "STATIONID".

<https://www.ecowitt.net/home/index?id=STATIONID>

Note: If you want to share your station data with other users, you may use the Share option under the Menu to create a share link.

It will show a page such as this, where you can look at today's data and historical data as well.

## Dashboard



## Graph display

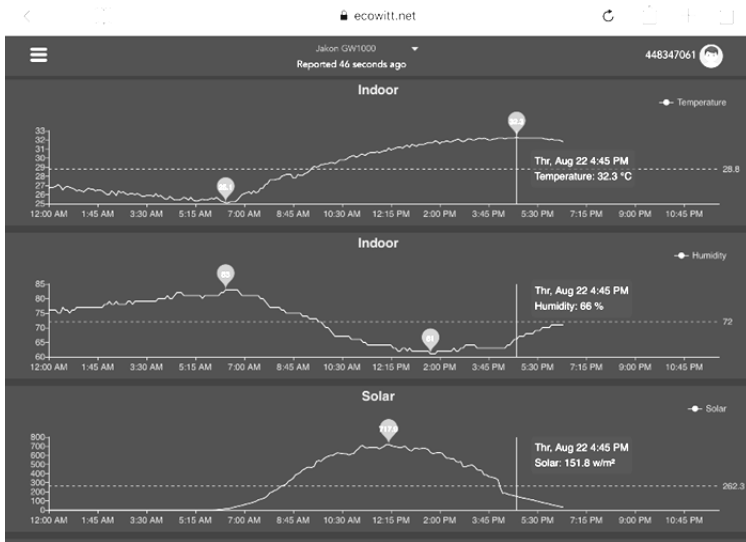

# List display

6:37 PM Thu Aug 22 ecowitt.net 73%

ikee GW1000  
Reported 13 seconds ago 448347061

Daily Aug 22, 2019

Time	Temperature (°C)	Humidity(%)	Dew Point(°C)	Feels Like(°C)	Temperature (°C)	Humidity(%)	Absolute(hPa)	Relative(hPa)	Wind Speed(m/s)	Wind Gust(m/s)	Wind Dir
2019-08-22 18:30	31.3	77	26.8	40.9	31.8	72	997.8	997.8	1.0	2.0	4
2019-08-22 18:25	31.5	77	26.9	41.3	31.8	71	997.7	997.7	1.1	1.5	2
2019-08-22 18:20	31.5	76	26.8	41.2	31.9	71	997.8	997.8	0.8	1.5	3
2019-08-22 18:15	31.6	76	26.9	41.4	32.0	71	997.7	997.7	0.9	2.0	2
2019-08-22 18:10	31.7	75	26.8	41.5	32.0	71	997.6	997.6	0.7	2.0	3
2019-08-22 18:05	31.8	75	26.8	41.6	32.0	71	997.6	997.6	0.8	2.6	2
2019-08-22 18:00	31.9	74	26.7	41.6	32.1	71	997.5	997.5	1.1	3.1	8
2019-08-22 17:55	31.9	75	26.9	41.9	32.0	70	997.5	997.5	1.1	3.6	7
2019-08-22 17:50	32.1	74	26.9	42.4	32.1	70	997.4	997.4	1.0	2.0	5
2019-08-22 17:45	32.2	74	27.0	42.6	32.1	70	997.4	997.4	1.7	2.6	1
2019-08-22 17:40	32.3	74	27.1	42.9	32.2	70	997.1	997.1	0.6	2.0	2
2019-08-22 17:35	32.5	73	27.0	43.1	32.2	69	997.3	997.3	0.9	2.6	6
2019-08-22 17:30	32.7	72	27.1	43.6	32.2	69	997.4	997.4	0.5	1.5	5

# Weather Map

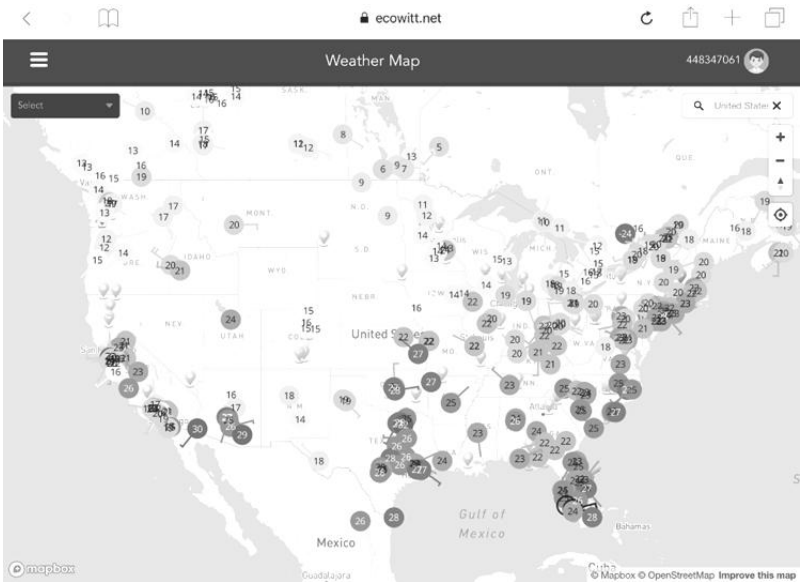

# Email Alerts

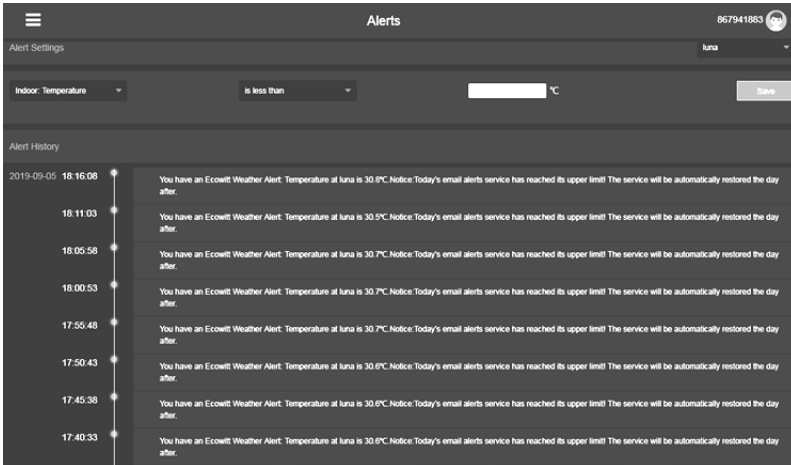

### 4.9.15.5 Customized server setup

For highly experienced users, it offers the option to send data to the user’s own server. Press the “setup” button to enter Customized setup screen,



**Figure : Server setup screen**



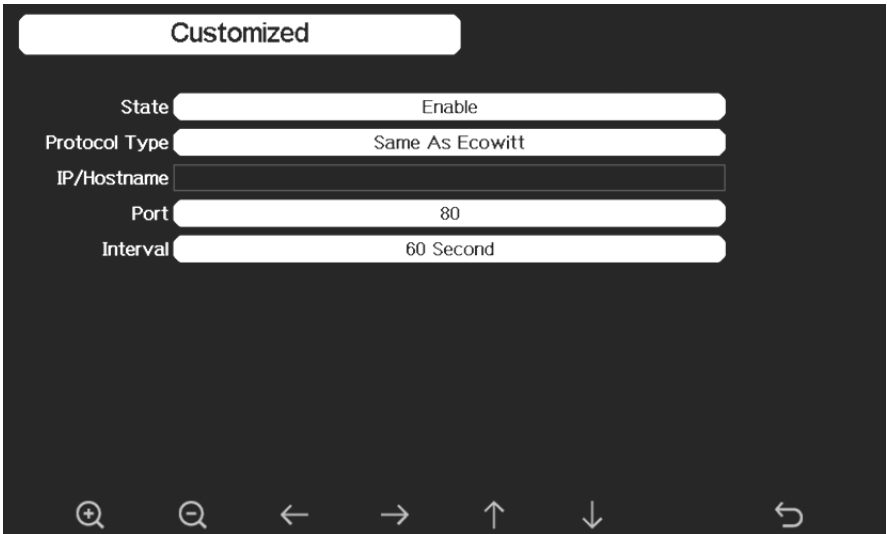
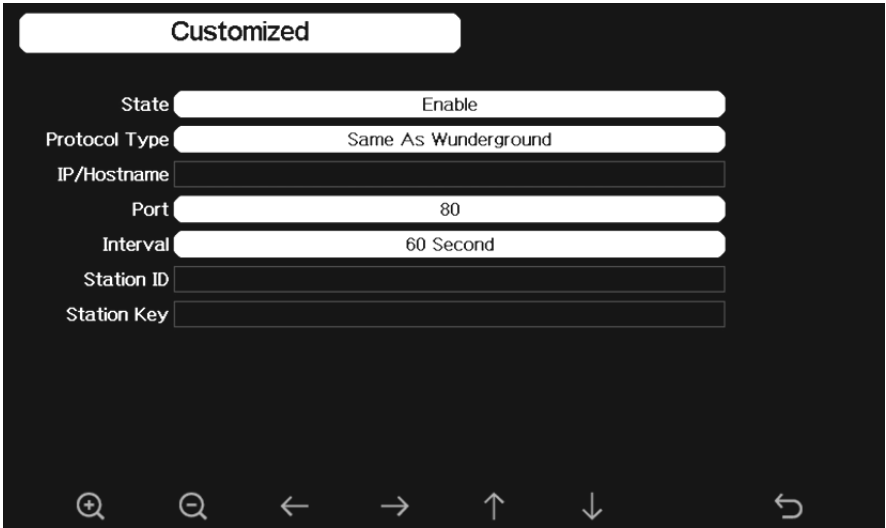

Select Enable button and select the protocol type. The website should has the same protocol with Wunderground or Ecowitt. Input all the information needed.



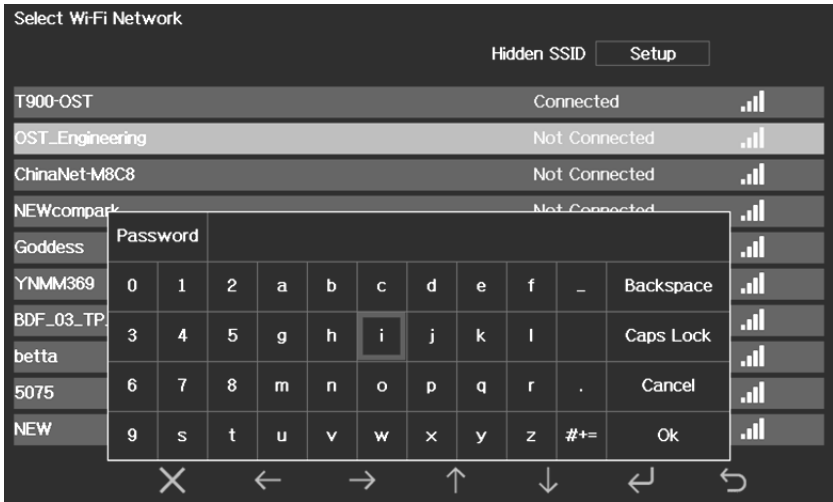

#### 4.9.16 Connect Console to Your Router: Wi-Fi scan

Entering this mode, system will display all the available Wi-Fi networks. Select the SSID that you want console to be connected with (only supports 2.4GHz band Wi-Fi network ), and enter passer word as required.











Press  or  key to select the Wi-Fi network. Press  key to confirm and enter the password. Press  key to return to normal display mode. It is possible that your network is not listed when Wi-Fi Scan is performed. Press  button and restart Wi-Fi Scan, this will usually solve the problem.









Only after connect to WLAN you can upload the data to weather website. If the Wi-Fi network connects successfully, the icon  will show on the left top of the console display. If the data upload to Wunderground.com successfully, the icon  will show on the left top of the console display.

If the Wi-Fi network you would like to connect is with a hidden SSID, please follow below steps to connect:

- 1) Press   to select Hidden SSID setup, and press  key

directly to enter.

2) Press  to highlight the SSID. Press  to display the keyboard and enter your SSID. Press     to scroll to the character and press  to enter the character. Press  to return to the setup page.

3) Press  to highlight the Password. Press  to display the keyboard and start to enter your password.. Press     to scroll to the character and press  to enter the character. Press  to return to the setup page.



4) Press  to highlight the “OK” button beside “Connect ” to start connecting.

After connected successfully, the status will display” Connected”.

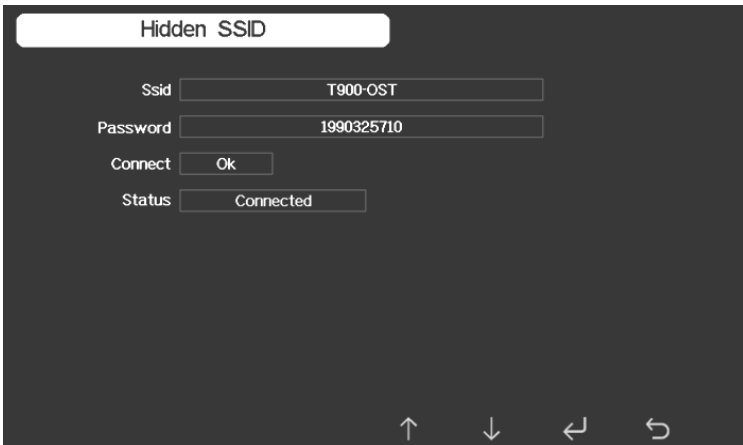
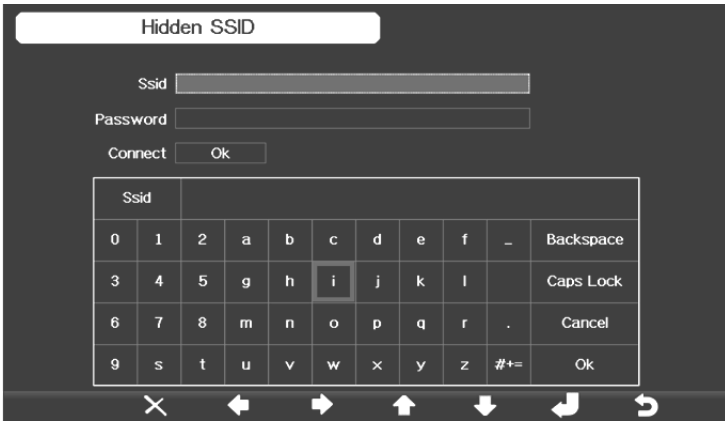



#### 4.9.17 Background

While in Menu Setting Mode, press  key to select Background Setup field, press  or  key to choose between dark background display and light background display

## 4.9.18 Alarm Setting Mode

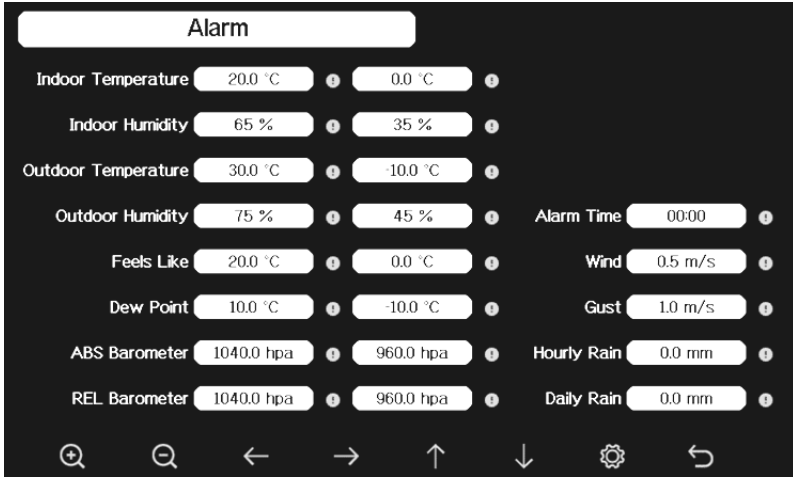







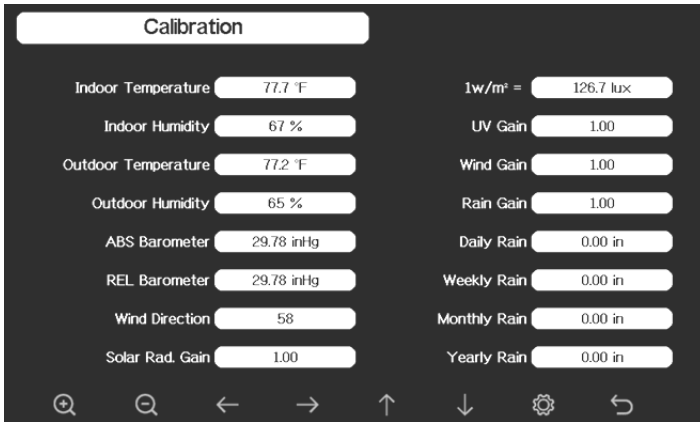

Icon	Description
	<b>Select key</b> Press this key to select the unit or scrolls the value
	<b>Select key</b> Press this key to select the unit or scrolls the value.
	<b>Left key</b> Press this key to select the set value.
	<b>Right key</b> Press this key to select the set value.
	<b>Up arrow key</b> Press this key to change the activated option field
	<b>Down arrow key</b> Press this key to change the activated option field
	<b>Set key</b> Press this key to select the Setting sub-Mode
	<b>Return key</b> Press this key to return to previous mode

The first row is high alarm value and the second row is low alarm value.





When weather alarm condition has been triggered, that particular alarm will sound for 120 second and the corresponding icon will flash until the weather condition doesn't meet the user set level. Press any key to mute the alarm.

### 4.9.19 Calibration Mode



Icon	Description
	<b>Select key</b> Press this key to select the unit or scrolls the value
	<b>Select key</b> Press this key to select the unit or scrolls the value.
	<b>Left key</b> Press this key to select the set value.
	<b>Right key</b> Press this key to select the set value.
	<b>Up arrow key</b> Press this key to change the activated option field
	<b>Down arrow key</b> Press this key to change the activated option field
	<b>Set key</b> Press this key to select the Setting sub-Mode

	<p><b>Return key</b> Press this key to return to previous mode</p>
-----------------------------------------------------------------------------------	------------------------------------------------------------------------

To adjust the parameter, press  to scroll to the parameter you wish to change. Press  to highlight the sign (positive vs. negative, if applicable) and significant digit. Press  or  to change the calibrated value.

Parameter	Type of Calibration	Default	Typical Calibration Source
Temperature	Offset	Current Value	Red Spirit or Mercury Thermometer (1)
Humidity	Offset	Current Value	Sling Psychrometer (2)
ABS Barometer	Offset	Current Value	Calibrated laboratory grade barometer
REL Barometer	Offset	Current Value	Local airport (3)
Wind Direction	Offset	Current Value	GPS, Compass (4)
Solar Radiation	Gain	1.00	Calibrated laboratory grade solar radiation sensor
1 w/m <sup>2</sup>	Gain	126.7 lux	Solar radiation conversion from lux to w/m <sup>2</sup> for wavelength correction (5)
Wind	Gain	1.00	Calibrated laboratory grade wind meter (6)
Rain	Gain	1.00	Sight glass rain gauge with an aperture of at least 4" (7)
Daily Rain	Offset	Current Value	Apply an offset if the weather station was not operating for the entire day.

Weekly Rain	Offset	Current Value	Apply an offset if the weather station was not operating for the entire week.
Monthly Rain	Offset	Current Value	Apply an offset if the weather station was not operating for the entire month.
Yearly Rain	Offset	Current Value	Apply an offset if the weather station was not operating for the entire year.

- (1) Temperature errors can occur when a sensor is placed too close to a heat source (such as a building structure, the ground or trees).

To calibrate temperature, we recommend a mercury or red spirit (fluid) thermometer. Bi-metal (dial) and digital thermometers (from other weather stations) are not a good source and have their own margin of error. Using a local weather station in your area is also a poor source due to changes in location, timing (airport weather stations are only updated once per hour) and possible calibration errors (many official weather stations are not properly installed and calibrated).

Place the sensor in a shaded, controlled environment next to the fluid thermometer, and allow the sensor to stabilize for 3 hours. Compare this temperature to the fluid thermometer and adjust the console to match the fluid thermometer.

- (2) Humidity is a difficult parameter to measure electronically and drifts over time due to contamination. In addition, location has an adverse affect on humidity readings (installation over dirt vs. lawn for example).

Official stations recalibrate or replace humidity sensors on a yearly basis. Due to manufacturing tolerances, the humidity is accurate to

$\pm 5\%$ . To improve this accuracy, the indoor and outdoor humidity can be calibrated using an accurate source, such as a sling psychrometer.

- (3) The display console displays two different pressures: absolute (measured) and relative (corrected to sea-level).

To compare pressure conditions from one location to another, meteorologists correct pressure to sea-level conditions. Because the air pressure decreases as you rise in altitude, the sea-level corrected pressure (the pressure your location would be at if located at sea-level) is generally higher than your measured pressure.

Thus, your absolute pressure may read 28.62 inHg (969 mb) at an altitude of 1000 feet (305 m), but the relative pressure is 30.00 inHg (1016 mb).

The standard sea-level pressure is 29.92 in Hg (1013 mb). This is the average sea-level pressure around the world. Relative pressure measurements greater than 29.92 inHg (1013 mb) are considered high pressure and relative pressure measurements less than 29.92 inHg are considered low pressure.

To determine the relative pressure for your location, locate an official reporting station near you (the internet is the best source for real time barometer conditions, such as [Weather.com](http://Weather.com) or [Wunderground.com](http://Wunderground.com)), and set your weather station to match the official reporting station.

- (4) Only use this if you improperly installed the weather station sensor array, and did not point the direction reference to true north.
- (5) The default conversion factor based on the wavelength for bright sunlight is  $126.7 \text{ lux} / \text{w/m}^2$ . This variable can be adjusted by photovoltaic experts based on the light wavelength of interest, but for most weather station owners, is accurate for typical applications,

such as calculating evapotranspiration and solar panel efficiency.

- (6) Wind speed is the most sensitive to installation constraints. The rule of thumb for properly installing a wind speed sensor is 4 x the distance of the tallest obstruction. For example, if your house is 20' tall and you mount the sensor on a 5' pole:

$$\text{Distance} = 4 \times (20 - 5)' = 60' \text{ or } = 4 \times (6.10 - 1.52) = 18.32\text{m.}$$

Many installations are not perfect and installing the weather station on a roof can be difficult. Thus, you can calibrate for this error with a wind speed multiplier.

In addition to the installation challenges, wind cup bearings (moving parts) wear over time.

Without a calibrated source, wind speed can be difficult to measure. We recommend using a calibrated wind meter (not included) and a constant speed, high speed fan.

- (7) The rain collector is calibrated at the factory based on the funnel diameter. The bucket tips every 0.01" or 0.1m of rain (referred to as resolution). The accumulated rainfall can be compared to a sight glass rain gauge with an aperture of at least 4" or 0.1m. Make sure you periodically clean the rain gauge funnel.

**Note:** The purpose of calibration is to fine tune or correct for any sensor error associated with the devices margin of error. Errors can occur due to electronic variation (example, the temperature sensor is a resistive thermal device or RTD, the humidity sensor is a capacitance device), mechanical variation, or degradation (wearing of moving parts, contamination of sensors).

Calibration is only useful if you have a known calibrated source you can compare it against, and is optional. This section discusses practices, procedures and sources for sensor calibration to reduce manufacturing and

degradation errors. Do not compare your readings obtained from sources such as the internet, radio, television or newspapers. The purpose of your weather station is to measure conditions of your surroundings, which vary significantly from location to location.

**Note:** UV Calibration MUST be performed every 2 to 3 months to improve results. Over time, UV Index may alter results based on bright and strong sunlight conditions. This is why diligent UV Calibration is recommended.

### 4.9.20 More

On the More page, you can set the Calibration for the optional multi-channel soil moisture/PM2.5/temp and humidity sensor. You can also view or manage all the sensors ID on the Sensors ID Setup page.

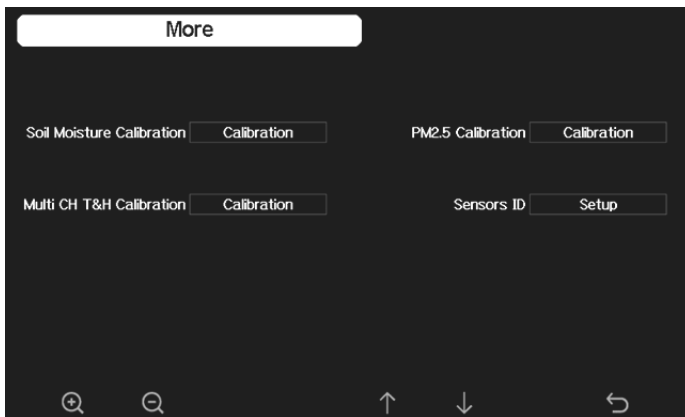



Calibration						
Channel	Soil Moisture	Now AD	0%AD	100%AD	Customize	Reset
1	3%	83	70	500	OFF	Reset
2	62%	320	70	500	OFF	Reset
3	0%	26	70	500	OFF	Reset
4	51%	268	70	500	OFF	Reset
5	29%	188	70	500	OFF	Reset
6	0%	26	70	500	OFF	Reset
7	66%	335	70	500	OFF	Reset
8	63%	323	70	500	OFF	Reset

Calibration			
Channel	PM2.5	PM25 Offset	Reset
1	34ug/m³	0	Reset
2	35ug/m³	0	Reset
3	42ug/m³	0	Reset
4	-	0	Reset

Calibration					
Channel	Temperature	Humidity	Temp. Offset	Humi. Offset	Reset
1	--	--	0.0	0	Reset
2	82.2°F	45%	0.0	0	Reset
3	80.8°F	46%	0.0	0	Reset
4	81.0°F	47%	0.0	0	Reset
5	81.0°F	46%	0.0	0	Reset
6	81.3°F	47%	0.0	0	Reset
7	14.7°F	49%	0.0	0	Reset
8	81.3°F	45%	0.0	0	Reset

Note:

To calibrate the optional soil moisture sensor, please refer to the manual of the WH51 soil moisture sensor.

To calibrate the PM2.5 sensor, you'll need to find a reliable source, such as professional devices from your local air quality service.

To calibrate the temp and humidity sensor, please refer to section 4.9.19.

### Sensor ID Setup

On this page you can set the following:

- View sensor ID, signal strength and battery power condition. 1-4 bars means 1-4 successful successive signal receptions without missed ones.
- Register the sensor when offline.
- Enable or disable the sensor.
- Input the Sensor ID when offline.



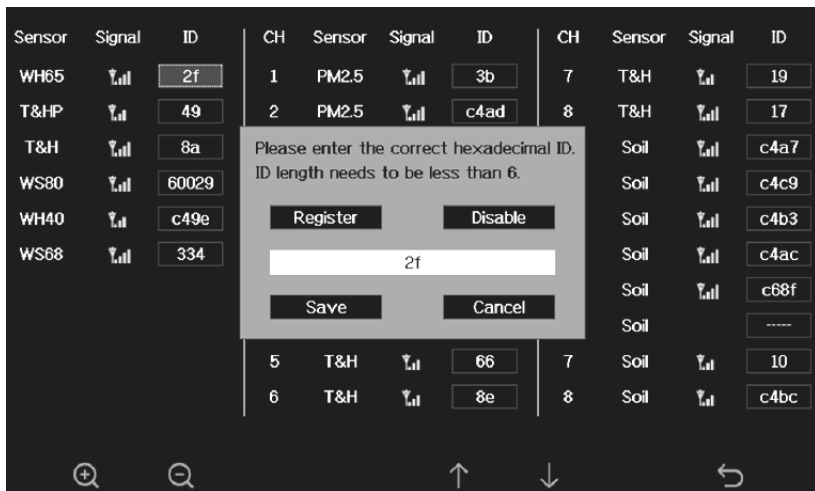



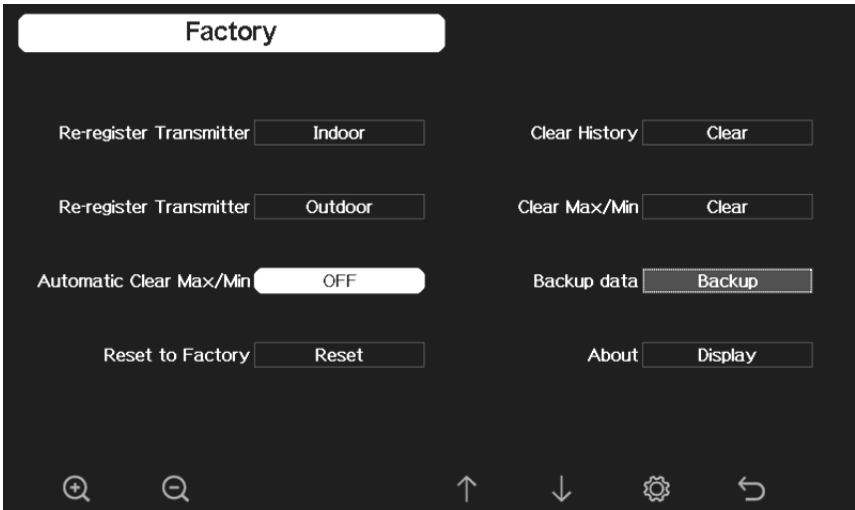

Sensor	Signal	ID	CH	Sensor	Signal	ID	CH	Sensor	Signal	ID
WH65	📶	2f	1	PM2.5	📶	3b	7	T&H	📶	19
T&HP	📶	49	2	PM2.5	📶	c4ad	8	T&H	📶	17
T&H	📶	8a	3	PM2.5	📶	5f	1	Soil	📶	c4a7
WS80	📶	60029	4	PM2.5	📶	3f	2	Soil	📶	c4c9
WH40	📶	c49e	1	T&H	📶	31	3	Soil	📶	c4b3
WS68	📶	334	2	T&H	📶	81	4	Soil	📶	c4ac
			3	T&H	📶	65	5	Soil	📶	c68f
			4	T&H	📶	e5	6	Soil		----
			5	T&H	📶	66	7	Soil	📶	10
			6	T&H	📶	8e	8	Soil	📶	c4bc



## 4.9.21 Factory reset



### 4.9.21.1 Re-register indoor transmitter

Press  or  key to select re-register indoor transmitter. Press  or  key to popup the Message Box "Register a new indoor transmitter?" Press  or  to select Yes or No. Press the  or  key to confirm the selection.

### 4.9.21.2 Re-register outdoor transmitter

Please reference section 5.13.1. Procedures and settings are similar to re-register indoor transmitter.

### 4.9.21.3 Automatic Clear Max/Min

To turn on/off automatically clear Max/Min record at 0:00hr every day.









Press  or  key to select Automatic clear Max/Min. Press  or











key to switch on/off.

When it is selected with ON option, min/max will be presented as daily min/max, and with OFF option selected, it is for history min/max record.









#### 4.9.21.4 Reset to Factory

Press  or  key to select Reset to Factory. Press  or  key to popup the Message Box "Reset to factory default?" Press  or  to select Yes or No. Press the  or  key to confirm the selection.





#### 4.9.21.5 Clear History





Press  or  key to select Clear History. Press  or  key to popup the Message Box "Clear the history record?" Press  or  to select Yes or No. Press the  or  key to confirm the selection.

#### 4.9.21.6 Clear Max/Min

Press  or  key to select Clear Max/Min. Press  or  key to popup the Message Box "Clear the max/min record?" Press  or  to select Yes or No. Press the  or  key to confirm the selection.

#### 4.9.21.7 Backup data

Press  or  key to select Backup data. Press  or  key to

popup the Message Box "Copy history data to SD card?" Press  or  to select OK or Cancel. Press the  or  key to confirm the selection.

Note: You need to insert a SD card(not included) into the console before using this function.

#### 4.9.21.8 About information

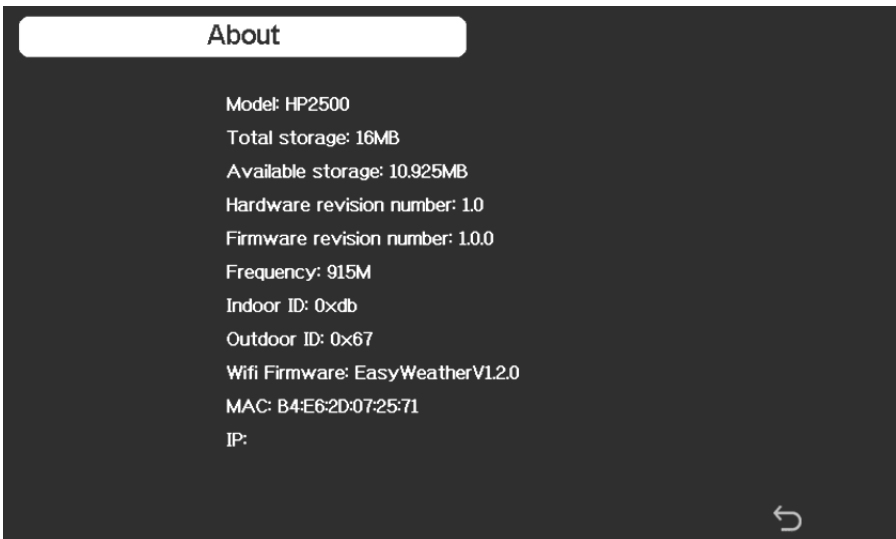

Note: This figure is just for reference(model and frequency will change according to different market). The actual display console may be with higher firmware version than this manual described because we will update the firmware occasionally.

## 5 Other Console Functions

### 5.1 Beaufort Wind Force Scale

If you have selected the use of Beaufort wind speed units, you can use the table below for reference. The Beaufort scale is based on qualitative wind conditions and how they would affect a ship's (frigate) sails (so yes, it is an "old" standard). It is therefore less precise than the other scales but is still in use in various locales.







Wind speed	Beaufort number	Description
0 - 1 mph, or 0 - 1.6 km/h	0	Calm
1 - 3 mph, or 1.6 - 4.8 km/h	1	Light air
3 - 7 mph, or 4.8 - 11.3 km/h	2	Light breeze
7 - 12 mph, or 11.3 - 19.3 km/h	3	Gentle breeze
12 - 18 mph, or 19.3 - 29.0 km/h	4	Moderate breeze
18 - 24 mph, or 29.0 - 38.6 km/h	5	Fresh breeze
24 - 31 mph, or 38.6 - 49.9 km/h	6	String breeze
31 - 38 mph, or 49.9 - 61.2 km/h	7	Near gale
38 - 46 mph, or 61.2 - 74.1 km/h	8	Gale
46 - 54 mph, or 74.1 - 86.9 km/h	9	Strong gale
55 - 63 mph, or 88.5 - 101.4 km/h	10	Storm
64 - 73 mph, or 103 - 117.5 km/h	11	Violent storm
74 mph and above, or 119.1 km/h and above	12	Hurricane

**Table 3: Beaufort wind force scale**

## 5.2 Weather Forecasting

The five weather icons are Sunny, Partly Cloudy, Cloudy, Rainy and Stormy, Snowy and Storm Snowy.

The forecast icon is based on the rate of change of barometric pressure. Please allow at least **one month** for the weather station to learn the barometric pressure over time.

<b>Sunny</b>	<b>Partly Cloudy</b>	<b>Cloudy</b>
		
Pressure increases for a sustained period of time	Pressure increases slightly or initial power up	Pressure decreases slightly
<b>Rainy</b>	<b>Stormy</b>	<b>Snowy</b>
		
Pressure decreases for a sustained period of time	Pressure rapidly decreases	Pressure decreases for a sustained period of time, and temperature $\leq 0^{\circ}\text{C}$
<b>Storm Snowy</b>		



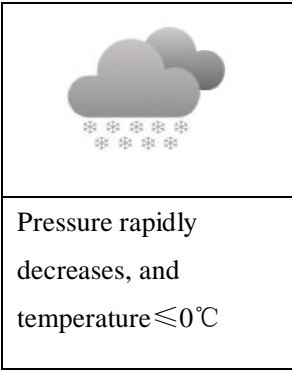

### 5.3 Lightning Alert

The lightning icon  will appear if the Dew Point exceeds 70 F. This means there is a chance of lightning storms forming.

### 5.4 Weather Forecasting Description and Limitations

In general, if the rate of change of pressure increases, the weather is generally improving (sunny to partly cloudy). If the rate of change of pressure decreases, the weather is generally degrading (cloudy, rainy or stormy). If the rate of change is relatively steady, it will read partly cloudy.









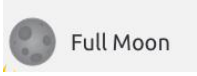







The reason the current conditions do not match the forecast icon is because the forecast is a prediction 24-48 hours in advance. In most locations, this prediction is only 70% accurate and it is a good idea to consult the National Weather Service for more accurate weather forecasts. In some locations, this prediction may be less or more accurate. However, it is still an interesting educational tool for learning why the weather changes.











The National Weather Service (and other weather services such as Accuweather and The Weather Channel) have many tools at their disposal to

predict weather conditions, including weather radar, weather models, and detailed mapping of ground conditions.

### 5.5 Moon Phase

In the event the moon phase is 100%, the icon  will appear in its place. In the event of 0%, the word “New Moon” will appear in its place.

Moon Phase	Image	Moon Phase	Image
Day 1		Day 14	
Day 2		Day 15	
Day 3		Day 16	
Day 4		Day 17	
Day 5		Day 18	
Day 6		Day 19	
Day 7		Day 20	
Day 8		Day 21	

Day 9		Day 22	
Day 10		Day 23	
Day 11		Day 24	
Day 12		Day 25	
Day 13 Full Moon		Day 26 New Moon	

# 6 Maintenance

The following steps should be taken for proper maintenance of your station

## Clean Rain Gauge

Check the rain gauge every 3 months. Rotate the funnel counterclockwise and lift it up. Clean the funnel and bucket with a damp cloth to remove any dirt, debris and insects. Spray the array lightly with insecticide, if there's a bug infestation.

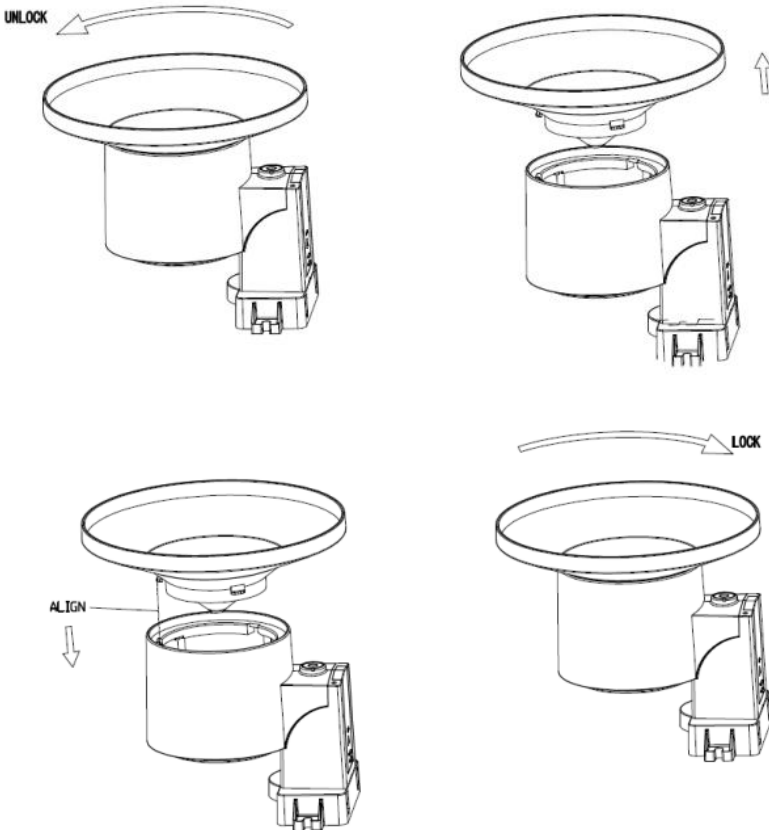

Figure 5: Rain gauge maintenance

### **Clean solar radiation sensor and solar panel**

The solar radiation sensor and solar panel of the outdoor sensor array need to be cleaned with a non-abrasive slightly damp cloth every 3 months.

### **Replacing batteries regularly**

Batteries of the outdoor sensor array should be replaced every 1-2 years. In applications where data dropouts cannot be tolerated, check the batteries every 3 months and apply a corrosion preventing compound (not included) on the battery terminals for protection.

### **Prevent snow build up**

In snowy environments, use anti-icing silicon spray on the top of the weather station, and rain collection top, to prevent snow build up.

### **Rain Gauge Accuracy Cross Check**

To tell if the rain gauge is accurate or not, it is not correct to compare to a rain meter nearby around. Because it is not necessary having a same rain intensity, even if they are not far from each other. To judge if your rain meter is correct or not, you may do the following:

1. Use a narrowed neck bottle that can sit under the rain gauge water outlet holes. Collect the water during a rain event and measure its weight. E.g. 353 g.
2. 353 g equals 353 ml, divided by rain collector size of 250 cm<sup>2</sup>, you get  $353/250 = 1.412 \text{ cm} = 14.1 \text{ mm}$ .
3. Compare the rain readings from your gateway to your local rain event reading, or a reading from a calibrated manual gauge, to see if they are matching or not.
4. Since there may be some water left in the tip bucket, and also some on the rain collector itself, the observed rain is normally slightly less than the actual rainfall, but this is normally within 5%. If the deviation is larger than this, then you can change rain calibration settings accordingly, or contact the customer service for replacement.

## 7 Troubleshooting Guide

Look through the following table and locate an issue or problem you are experiencing in the left column and read possible solutions in the right column.

Problem	Solution
<p>Wireless remote (thermo-hygrometer) not reporting in to console.</p> <p>There are dashes on the display console.</p>	<p>The maximum line of sight communication range is about 600'. Move the sensor assembly closer to the display console.</p> <p>Resynchronize the remote sensor(s). Install a fresh set of batteries in the remote sensor(s).</p> <p>Make sure the remote sensors are not transmitting through solid metal (acts as an RF shield), or earth barrier (down a hill).</p> <p>Radio Frequency (RF) Sensors cannot transmit through metal barriers (example, aluminum siding) or multiple, thick walls.</p> <p>Move the display console around electrical noise generating devices, such as computers, TVs and other wireless transmitters or receivers.</p>
<p>Outdoor sensor does not communicate to the display console.</p>	<p>The sensor may have initiated properly and the data is registered by the console as invalid, and the console must be reset. Press the reset button as described in Section Installation.</p> <p>With an open ended paperclip, press the reset button for 3 seconds to completely discharge the voltage.</p>

Take out the batteries and wait one minute, while covering the solar panel to drain the voltage.

Put batteries back in and re-sync with console by powering down and up the console with the sensor array about 10 feet/3m away.

Bring the sensor array inside the house (you can disconnect it from the rest of the sensors). The LED next to the battery compartment will flash according to the reporting time on the specifications. If the LED is not flashing as that...

Replace the batteries in the sensor.

If the batteries were recently replaced, check the polarity. If the sensor is flashing normally, proceed to the next step.

There may be a temporary loss of communication due to reception loss related to interference or other location factors,



or the batteries may have been changed in the sensor and the console has not been reset. The solution may be as simple as **powering down and up the console.**

Replace the batteries in the sensor.

With the sensor and console 10 feet away from each other, remove AC power from the display console and wait 10 seconds. Re-connect power.

<p>Temperature sensor reads too high in the day time.</p>	<p>Make certain that the sensor is not too close to heat generating sources or structures, such as buildings, pavement, walls or air conditioning units.</p> <p>Use the calibration feature to offset installation issues related to radiant heat sources.</p>
<p>Absolute pressure does not agree with official reporting station</p>	<p>You may be viewing the relative pressure, not the absolute pressure.</p> <p>Select the absolute pressure. Make sure you properly calibrate the sensor to an official local weather station. Reference Section 4.9.19 for details.</p>
<p>Rain gauge reports rain when it is not raining</p>	<p>An unstable mounting solution (sway in the mounting pole) may result in the tipping bucket incorrectly incrementing rainfall. Make sure you have a stable, level mounting solution.</p>



<p>Data not reporting to Wunderground.com</p>	<ol style="list-style-type: none"> <li>1. Confirm your password is correct. It is the password you registered on Wunderground.com. Your Wunderground.com password cannot begin with a non-alphanumeric character (a limitation of Wunderground.com, not the station). Example, \$oewkrf is not a valid password, but oewkrf\$ is valid.</li> <li>2. Confirm your station ID is correct. The station ID is all caps, and the most common issue is substituting an O for a 0 (or visa versa). Example, KAZPHOEN11, not KAZPHOEN11</li> <li>3. If there's a number "1" on the station key, try to input the lower case of letter "L" to replace it.</li> <li>4. Make sure the date and time is correct on the console. If incorrect, you may be reporting old data, not real time data.</li> <li>5. Make sure your time zone is set properly. If incorrect, you may be reporting old data, not real time data.</li> </ol> <p>Check your router firewall settings. The console sends data via <b>Port 80</b>.</p>
<p>No Wi-Fi connection</p>	<ol style="list-style-type: none"> <li>1. Check for Wi-Fi signal strength symbol on the display . If wireless connectivity is successful and reporting to Wunderground.com, the Wi-Fi icon  will be displayed the home page.</li> <li>2. Make sure your modem Wi-Fi settings are correct (network name, password and security settings).</li> </ol>

## 8 Specifications

**Note:** Out of range values will be displayed using “---”

Outdoor sensor	Specification
Transmission distance in open field	200 m (600 ft.)
RF Frequency	433/ 868/ 915MHz depending on location (North American: 915MHz; Europe: 868MHz; Other areas: 433MHz)
Temperature range	-40 °C – 60 °C (-40 °F - 140 °F)
Temperature accuracy	±1 °C, or ±2 °F
Temperature resolution	0.1 °C, or 0.1 °F
Humidity range	1% ~ 99%
Humidity accuracy	±4%
Humidity resolution	1%
Rain volume display range	0 – 9000 mm
Rain volume accuracy	±5%
Rain volume resolution	0.1mm/0.01inch
Wind speed range	0 – 40 m/s (0 ~ 89mph)
Wind speed accuracy	<10m/s, +/-0.5m/s ≥10m/s, +/-5%
Wind direction accuracy	<10m/s, TBA ≥10m/s, ±15°
UV-Index range	0 - 15
Light range	0 – 200 kLux
Light accuracy	±15%
Sensor reporting interval	Anemometer sensor : 4.8s (wind speed sampling: 4s when less than 3m/s; 2s when wind speed > 3m/s but < 5m/s 1s when wind speed > 5m/s ) rain gauge sensor: 49s

**Table 7: Outdoor sensor specification****Note:**

- When the maximum wind speed of the last 4s is  $\geq 5\text{m/s}$ , the wind speed is detected by 1s; when the maximum wind speed of the last 4s is  $\geq 3\text{m/s}$  and less than  $5\text{m/s}$ , the wind speed is detected by 2s; when the maximum wind speed of the last 4s is  $< 3\text{m/s}$ , the wind speed is detected by 4s.
- The wind speed reading will be a real-time value (The latest sampling data will be reporting to the receiver).
- The wind gust reading will be the max wind speed in the past 28s.
- When the wind speed is lower than  $5\text{m/s}$ , the dispersion of wind direction will increase.

Indoor sensor	Specification
Temperature range	-10 °C – 60 °C (14 °F - 140 °F)
Temperature resolution	0.1 °C, or 0.1 °F
Humidity range	10% ~ 99%
Humidity resolution	1%
Barometric pressure range	300 – 1,100 hPa (8.85 – 32.5 inHg)
Barometric pressure accuracy	$\pm 3$ hPa in 700 – 1,100 hPa range
Barometric pressure resolution	0.1 hPa (0.01 inHg)
Sensor reporting interval	60 seconds
Alarm Duration	120 seconds

**Table 8: Indoor sensor specification**

Power	Specification
Base station/console	5V DC Adapter (included)
Indoor sensor	2 x AA 1.5 Alkaline batteries (not included)
Rain gauge sensor	1 x AA 1.5V LR6 Alkaline (not included), or 1 x AA 1.5V Lithium battery (not included)
Anemometer sensor	Solar panel (built-in): 6.5V/4mA
Anemometer sensor (backup)	2 x AA 1.5V Lithium battery (not included)

**Table 9: Power specification**

Note: The primary power source for the outdoor sensor is the solar panel. When available solar power (light over recent period) is insufficient, the batteries will be used. In outdoor climates that frequently have sustained temperatures below 0 °C (or 32 °F) the use of Lithium batteries is strongly suggested as these are performing better than Alkaline batteries under such circumstances.

## **9 Warranty Information**

**We disclaim any responsibility for any technical error or printing error, or the consequences thereof.**

**All trademarks and patents are recognized.**

We provide a 1-year limited warranty on this product against manufacturing defects, or defects in materials and workmanship.

This limited warranty begins on the original date of purchase, is valid only on products purchased, and only to the original purchaser of this product. To receive warranty service, the purchaser must contact us for problem determination and service procedures.

This limited warranty covers only actual defects within the product itself and does not cover the cost of installation or removal from a fixed installation, normal set-up or adjustments, or claims based on misrepresentation by the seller, or performance variations resulting from installation-related circumstances.