

# **7-IN-1 WIRELESS SOLAR POWERED WEATHER SENSOR**

## **Operation Manual**

**Model: WS69**

Thank you for purchasing this 7-in-1 Wireless Solar Powered Weather Sensor ( built-in: Thermo-hygrometer / Rain Gauge / Wind Speed Sensor/ Wind Direction Sensor, Light and UV sensor, Solar panel Sensor )! This unit measures outdoor temperature and humidity, wind direction, rainfall, wind speed, wind gust, UV & light, Solar light intensity and UV index data. The data can be received by the Wi-Fi gateway(sold separately) and can be viewed using the WS View Plus/ Ecowitt App mobile application (after Wi-Fi configuration on the gateway has been completed).

To ensure the best product performance, please read this manual and retain it for future reference.

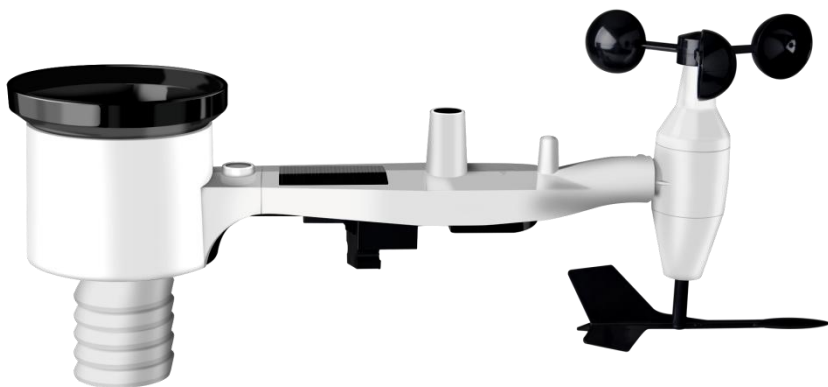



- \* Please scan the QR code to read English manual and keep it for future reference
- \* Bitte scannen Sie den QR-Code zudeutsche Anleitung lesen und aufbewahren fürZukunftsbezug
- \* Si prega di scansionare il codice QR perleggi il manuale italianoe conservarlo perReferenza futura

## Instruction manuals

<https://www.ecowitt.com/support/download/180>

## Help

Our product is continuously changing and improving, particularly online services and associated applications. To download the latest manual and additional help, please contact our technical support team:

[support@ecowitt.com](mailto:support@ecowitt.com)

[support.eu@ecowitt.net](mailto:support.eu@ecowitt.net) (EU/UK)



MADE IN CHINA



AC WORKS CONSULTING Srl  
Via Vilfredo Pareto 125,47521  
Casena(FC),ITALY

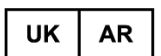

HUA TENG LIMITED  
3 Glass Street, Hanley, Stoke On Trent,  
ST1 2ET United Kingdom

# 1 Table of Contents

1 TABLE OF CONTENTS .....	1
2 WARNINGS AND CAUTIONS .....	2
3 UNPACKING .....	3
4 FEATURES .....	4
5 SET UP GUIDE .....	5
5.1 PRE INSTALLATION CHECKOUT .....	5
5.2 SITE SURVEY .....	5
5.3 SENSOR PACKAGE ASSEMBLY .....	6
5.3.1 Install U-bolts and metal plate .....	7
5.3.2 Install wind vane .....	9
5.3.3 Install wind speed cups .....	9
5.3.4 Install Batteries in sensor package .....	10
5.3.5 Mount assembled outdoor sensor package .....	11
5.3.6 Reset Button and Transmitter LED .....	14
5.4 BEST PRACTICES FOR WIRELESS COMMUNICATION .....	14
6 SETUP GUIDE USING WI-FI GATEWAY .....	16
6.1 REPLACING AN EXISTING SENSOR UNIT .....	16
7 MAINTENANCE .....	17
8 SPECIFICATIONS .....	19
9 WARRANTY INFORMATION .....	21

## 2 Warnings and Cautions

### Warning:

- Any metal object may attract a lightning strike, including your weather station mounting pole. Never install the weather station in a storm.
- If you are mounting the weather station to a house or structure, consult a licensed electrician for proper grounding. A direct lightning strike to a metal pole can damage or destroy your home.
- Installing your weather station in a high location may result in injury or death. Perform as much of the initial check out and operation on the ground and inside a building or home. Only install the weather station on a clear, dry, day.

### 3 Unpacking

Open your weather station box and inspect that the contents are intact (nothing broken) and complete (nothing missing). Inside you should find the following:

QT	Item Description
1	Outdoor Sensor Body with built-in: Thermo-hygrometer / Rain Gauge / Wind Speed Sensor/ Wind Direction Sensor, Light and UV sensor, Solar panel
1	Wind speed cups (to be attached to outdoor sensor body)
1	Wind vane (to be attached to outdoor sensor body)
2	U-Bolts for mounting on a pole
4	Threaded nuts for U-Bolts (M6 size)
1	Metal mounting plate to be used with U-Bolts
1	Wrench for M6 bolts
1	User manual (this manual)

**Table 1: Package content**

If components are missing from the package, or broken, please contact customer service to resolve the issue.

**Note:** Batteries for the outdoor sensor package are **not included**. You will need 2 AA size batteries, alkaline or Lithium batteries (Lithium recommended for colder climates).

## 4 Features

- Measures outdoor temperature and humidity wind direction, rainfall, wind speed, wind gust, UV & light, Solar light intensity and UV index data.
- No display, need to work with the WIFI gateway to complete the WIFI configuration on our WS View Plus/ Ecowitt App.
- After the WIFI configuration, the live weather data can be viewed directly on the WS View Plus/ Ecowitt App.
- Supports uploads to WU/Weather Cloud/WOW. The history graph of your WU station ID can be viewed on the WU Dashboard on the WS View Plus/ Ecowitt App.
- Works with WS2910/HP2551/HP3500/WS2320/HP2561/HP3501 Weather Station display console(sold separately). The outdoor sensor and display console should be at the same frequency.

## 5 Set up Guide

### 5.1 Pre Installation Checkout

To complete assembly you will need a Philips screwdriver (size PH0) and a wrench (size M6; included in package).

**Note:** We suggest you assemble all components of the weather station, including console in one location so you can easily test functionality. After testing, place the outdoor sensor package in the desired location. Note, however, that movement during assembly, and movement after assembly can cause the rain sensor to “falsely” register rain. It is therefore best if you do not connect the console to any Internet services until you have reset these false readings using the console. The errant values may be hard to remove from Internet services if you do not reset first.

**Attention:**

- Follow suggested order for battery installation (outdoor sensor first, console second)
- Ensure batteries are installed with correct polarity (+/-)
- Do not mix old and new batteries
- Do not use rechargeable batteries
- If outdoor temperature may go below 32F or 0C for prolonged periods, Lithium based batteries are suggested over alkaline type batteries for the outdoor sensor array

### 5.2 Site Survey

Perform a site survey before installing the weather station. Consider the following:

1. You must clean the rain gauge every few months and change the

- batteries every 2-3 years. Provide easy access to the weather station.
2. Avoid radiant heat transfer from buildings and structures. In general, install the sensor array at least 5' or 1.52m from any building, structure, ground, or roof top.
  3. Avoid wind and rain obstructions. The rule of thumb is to install the sensor array at least four times the distance of the height of the tallest obstruction. For example, if the building is 20' or 6.10m tall and the mounting pole is 6' or 1.83m tall, install the sensor array  $4 \times (20 - 6)' = 56'$  or  $4 \times (6.1 - 1.83) = 17.08\text{m}$  away.
  4. Mount the sensor array in direct sunlight for accurate temperature readings.
  5. Installing the weather station over sprinkler systems or other unnatural vegetation may affect temperature and humidity readings. We suggest mounting the sensor array over natural vegetation.
  6. Wireless Range. Radio communication between receiver and transmitter in an open field can reach a distance of up to 330 feet or 100 meter, providing there are no interfering obstacles such as buildings, trees, vehicles and high voltage lines. Wireless signals will not penetrate metal buildings. Under most conditions, the maximum wireless range is 100' or 30m.
  7. Radio Interference. Computers, radios, televisions and other sources can interfere with radio communications between the sensor array and console. Please take this into consideration when choosing console or mounting locations. Make sure your display console is at least five feet or 1.52 meter away from any electronic device to avoid interference.

### **5.3 Sensor Package Assembly**

See Figure 1 to locate and understand all the parts of the outdoor sensor package once fully assembled.



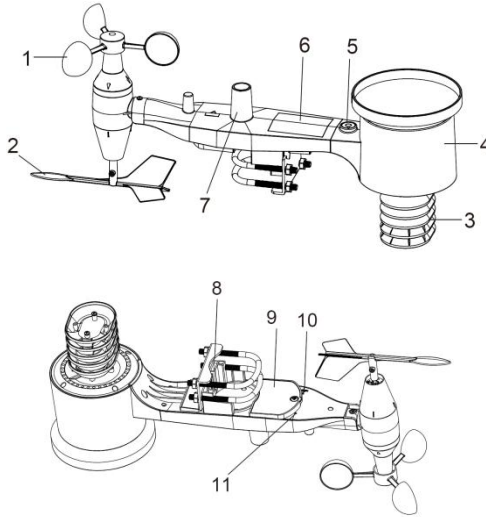

**Figure 1: Sensor assembly components**

1 Wind speed cups	7 Light sensor and UV sensor
2 Wind vane	8 U-Bolts
3 Thermo- and hygro-meter sensors	9 Battery compartment door
4 Rain collector	10 Reset button
5 Bubble level	11 LED (red) to indicate data transmission
6 Solar panel	

**Table 2: Sensor assembly detailed items**

### 5.3.1 Install U-bolts and metal plate

Installation of the U-bolts, which are in turn used to mount the sensor package on a pole, requires installation of an included metal plate to receive the U-bolt ends. The metal plate, visible in Figure 2 on the right side, has four holes through which the ends of the two U-Bolts will fit. The plate itself is inserted in a groove on the bottom of the unit (opposite side of solar panel). Note that one side of the plate has a straight edge (which goes into the groove), the other side is bent at a 90-degree angle

and has a curved profile (which will end up “hugging” the mounting pole). Once the metal plate is inserted, remove nuts from the U-Bolts and insert both U-bolts through the respective holes of the metal plate as shown in Figure 2.

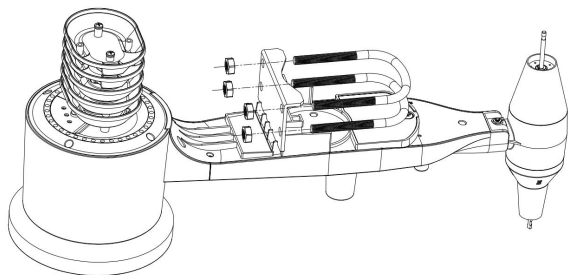

**Figure 2: U-Bolt installation**

Loosely screw on the nuts on the ends of the U-bolts. You will tighten these later during final mounting. Final assembly is shown in Figure 3.

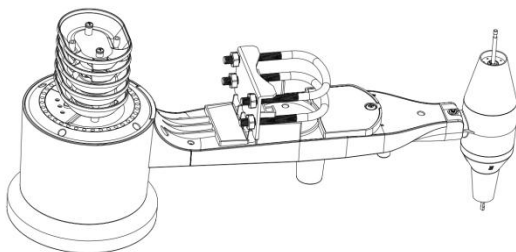
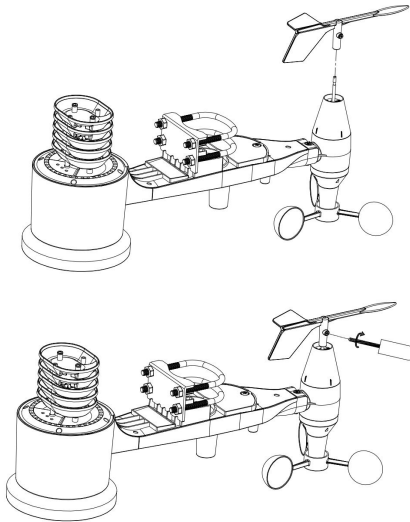

**Figure 3: U-Bolts and nuts installed**

The plate and U-Bolts are not yet needed at this stage but doing this now may help avoid damaging wind vane and wind speed cups later on. Handling of the sensor package with wind vane and speed cups installed to install these bolts is more difficult and more likely to lead to damage.

### 5.3.2 Install wind vane

Push the wind vane onto the shaft on the bottom side of the sensor package, until it goes no further, as shown on the left side in Figure 4. Next, tighten the set screw, with a Philips screwdriver (size PH0), as shown on the right side, until the wind vane cannot be removed from the axle. Make sure the wind vane can rotate freely. The wind vane's movement has a small amount of friction, which is helpful in providing steady wind direction measurements.



**Figure 4: Wind vane installation diagram**

### 5.3.3 Install wind speed cups

Push the wind speed cup assembly onto the shaft on the opposite side of the wind vane, as shown in Figure 5 on the left side. Tighten the set screw, with a Philips screwdriver (size PH0), as shown on the right side. Make sure the cup assembly can rotate freely. There should be no noticeable friction when it is turning.

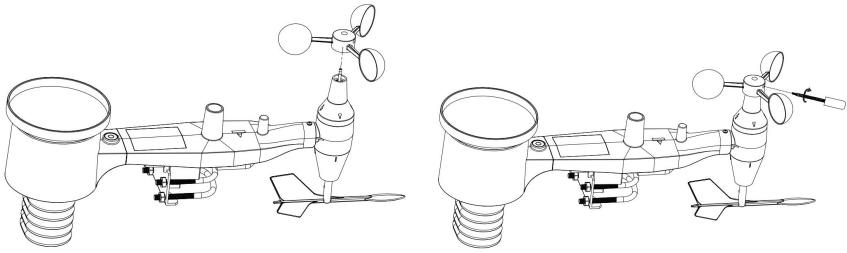

**Figure 5: Wind speed cup installation diagram**

### 5.3.4 Install Batteries in sensor package

Open the battery compartment with a screwdriver and insert 2 AA batteries in the battery compartment. The LED indicator on the back of the sensor package (item 9) will turn on for four seconds and then flash once every 16 seconds indicating sensor data transmission. If you did not pay attention, you may have missed the initial indication. You can always remove the batteries and start over, but if you see the flash once every 16 seconds, everything should be OK.

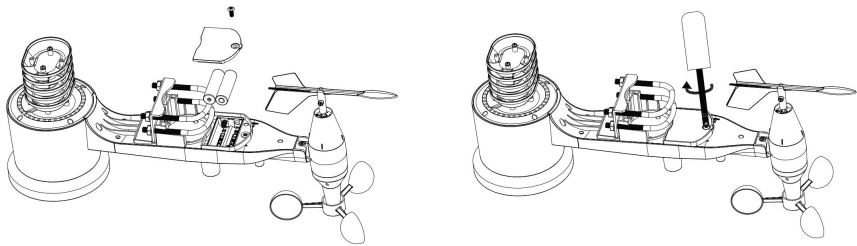

**Figure 6: Battery installation diagram**

**Note:** If LED does not light up or is on permanently, make sure the battery is inserted the correct way and inserted fully, starting over if necessary. Do not install the batteries backwards as it may permanently damage the outdoor sensor.

**Note:** We recommend Lithium batteries for cold weather climates, but alkaline batteries are sufficient for most climates. Rechargeable batteries have lower voltages and should never be used.

### **5.3.5 Mount assembled outdoor sensor package**

#### **5.3.5.1 Before you mount**

Before proceeding with the outdoor mounting detailed in this section, you may want to skip to setup instructions in section 5.5 and onwards first, while you keep the assembled outdoor sensor package nearby (although preferably not closer than 5 ft. or 1.53m from the console). This will make any troubleshooting and adjustments easier and avoids any distance or interference related issues from the setup.

After setup is complete and everything is working, return here for outdoor mounting. If issues show up after outdoor mounting they are almost certainly related to distance, obstacles etc.

### 5.3.5.2 Mounting

You can attach a pipe to a permanent structure and then attach the sensor package to it (see Figure 7).

The U-Bolts will accommodate a pipe diameter of 1-2 inches (pipe not included).

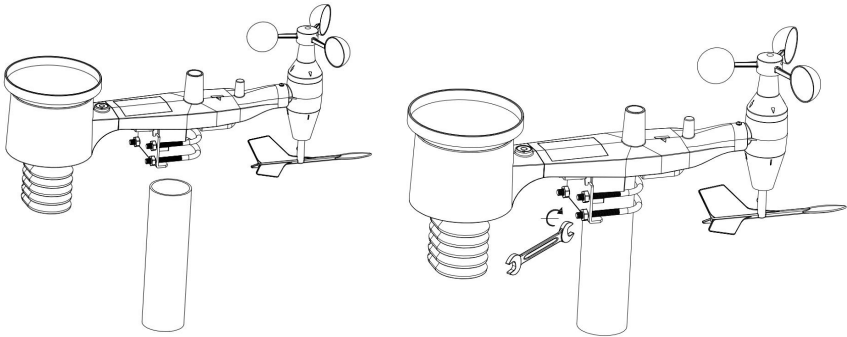

**Figure 7: Sensor package mounting diagram**

Make sure the mounting pipe is vertical, or very close to it. Use a level if needed.

Finally, place the sensor package on top of the prepared mounting pipe. The U-Bolts should be loose enough to allow this but loosen the nuts as necessary. Once placed, hand tightens all four nuts, taking care to do so evenly. Do not use a wrench yet!

Now you will need to align the whole package in the proper direction by rotating it on top of the mounting pipe as needed. Locate the arrow labeled “WEST” that you will find on top of the sensor package right next to the light sensor, on the opposite side of the solar panel. You must rotate the whole sensor package until this arrow points due west. To achieve proper alignment, it is helpful to use a compass (many cell phones have a compass application). Once rotated in the correct

orientation, lightly tighten the bolts a little more (use a wrench) to prevent further rotation.

**Note:** The orientation to WEST is necessary for two reasons. The most important one is to position the solar panel and light sensor in the most advantageous position for recording solar radiation and charging internal capacitors. Secondly it causes a zero reading for wind direction to correspond to due NORTH, as is customary. This orientation is correct for installations in the northern hemisphere. If you are installing in the southern hemisphere, the correct orientation to achieve the same optimal positioning is to have the “WEST” arrow actually point due EAST! This has the side effect, however, of lining up the 0 reading of the wind direction with SOUTH. This needs to be corrected using a 180-degree offset in the calibration settings (see section 6.9.2 ).

Now look at the bubble level. The bubble should be fully inside the red circle. If it is not, wind direction, speed, and rain readings may not operate correctly or accurately. Adjust the mounting pipe as necessary. If the bubble is close, but not quite inside the circle, and you cannot adjust the mounting pipe, you may have to experiment with small wooden or heavy cardboard shims between the sensor package and the top of the mounting pole to achieve the desired result (this will require loosening the bolts and some experimentation).

Make sure you check, and correct if necessary, the westerly orientation as the final installation step, and now tighten the bolts with a wrench. Do not over tighten, but make sure strong wind and/or rain cannot move the sensor package.

**Note:** If you tested the full assembly indoors and then came back here for instructions and mounted to sensor package outdoor you may want to make some further adjustments on the console. The transportation from indoor to outdoor and handling of the sensor is likely to have “tripped” the rainfall sensing bucket one or more

times and consequently the console may have registered rainfall that did not really exist. You can use console functions to clear this from history. Doing so is also important to avoid false registration of these readings with weather services.

### 5.3.6 Reset Button and Transmitter LED

In the event the sensor array is not transmitting, reset the sensor array.

Using a bent-open paperclip, press and hold the **RESET BUTTON** (see Figure 8) to affect a reset: the LED turns on while the RESET button is depressed, and you can now let go. The LED should then resume as normal, flashing approximately once every 16 seconds.

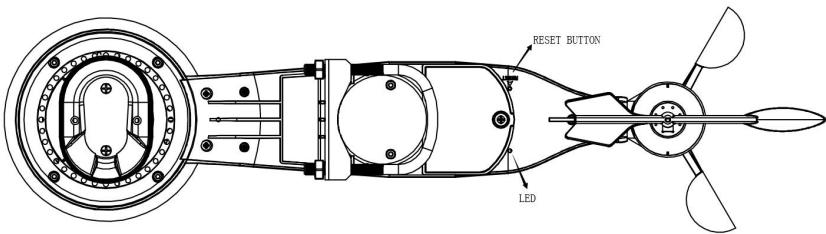

**Figure 8: Reset button and Transmitter LED location**

## 5.4 Best Practices for Wireless Communication

Wireless (RF) communication is susceptible to interference, distance, walls and metal barriers. We recommend the following best practices for trouble free wireless communication between both sensor packages and the console:

- **Electro-Magnetic Interference (EMI).** Keep the console several feet away from computer monitors and TVs.
- **Radio Frequency Interference (RFI).** If you have other devices operating on the same frequency band as your indoor and/or outdoor



sensors and experience intermittent communication between sensor package and console, try turning off these other devices for troubleshooting purposes. You may need to relocate the transmitters or receivers to avoid the interference and establish reliable communication. The frequencies used by the sensors are one of (depending on your location): 433, 868, or 915 MHz (915 MHz for United States).

- **Line of Sight Rating.** This device is rated at 300 feet or 100 meter line of sight (under ideal circumstances; no interference, barriers or walls), but in most real-world scenarios, including a wall or two, you will be able to go about 100 feet or 30 meter.
- **Metal Barriers.** Radio frequency will not pass through metal barriers such as aluminum siding or metal wall framing. If you have such metal barriers and experience communication problems, you must change the placement of sensor package and or console.

The following table shows different transmission media and expected signal strength reductions. Each “wall” or obstruction decreases the transmission range by the factor shown below.

Medium	RF Signal Strength Reduction
Glass (untreated)	5-15%
Plastics	10-15%
Wood	10-40%
Brick	10-40%
Concrete	40-80%
Metal	90-100%

**Table 3: RF Signal Strength reduction**

## **6 Setup Guide using Wi-Fi Gateway**

If you wish to view the sensor data on your mobile device, you need to pair this sensor device with the Wi-Fi gateway (sold separately), or another compatible display console device(sold separately).

Before you can use the mobile application to connect to the Wi-Fi gateway, it must be configured on your Wi-Fi network. Instructions may be found in the gateway manual.

### **6.1 Replacing an existing sensor unit**

If this sensor is a replacement for a previous unit, ensure the previous unit is powered down. Also unplug the Wi-Fi gateway from the USB connection, wait a few seconds, and re-connect the gateway to USB power.

Now simply insert the battery to power up the sensor unit, and the Wi-Fi gateway will quickly pick up the sensor information. It is best to always do this in the vicinity of the Wi-Fi gateway to rule out distance or signal interference effects, and to move the unit to the final location once correct configuration is confirmed.

## 7 Maintenance

The following steps should be taken for proper maintenance of your station

1. Clean the rain gauge once every 3 months. Rotate the funnel counter-clockwise and lift to expose the rain gauge mechanism, and clean with a damp cloth. Remove any dirt, debris and insects. If bug infestation is an issue, spray the array lightly with insecticide.



**Figure 9: Rain gauge installation and maintenance**

1. Clean the solar radiation sensor and solar panel every 3 months with a non-abrasive slightly damp cloth.
2. Replace batteries every 1-2 years. If left in too long, the batteries may leak due to environmental challenges. In harsh environments, inspect the batteries every 3 months (while cleaning the solar panel).

3. When replacing the batteries, apply a corrosion preventing compound on the battery terminals, available at Amazon and most hardware stores.
4. In snowy environments, spray the top of the weather station with anti-icing silicon spray to prevent snow build up.

## 8 Specifications

**Note:** Out of range values will be displayed using “---”:

Outdoor 7-in-1 sensor	Specification
Transmission distance in open field	100 m (330 ft.)
RF Frequency	433/868/915 MHz depending on location
Temperature range	-40°C – 60°C (-40°F - 140°F)
Temperature accuracy	± 1°C, or ± 2°F
Temperature resolution	0.1°C, or 0.1°F
Humidity range	10% ~ 99%
Humidity accuracy	± 5%
Humidity resolution	1%
Rain volume display range	0 – 6000 mm
Rain volume accuracy	± 10%
Rain volume resolution	0.3 mm (for volume < 1,000 mm) 1 mm (for volume ≥ 1,000 mm), or 0.01 in (for volume < 100 in) 1 mm (for volume ≥ 100 in)
Wind speed range	0 – 50 m/s (0 ~ 100 mph)
Wind speed accuracy	± 1 m/s (speed < 5 m/s) ± 10% (speed ≥ 5 m/s), or ± 0.1 mph (speed < 11 mph) ± 10% (speed ≥ 11 mph)
UV-Index range	0 - 15
Light range	0 – 200 kLux
Light accuracy	± 15%
Sensor reporting interval	16 seconds

**Table 4: Outdoor sensor specification**

<b>Power</b>	<b>Specification</b>
7-in-1 weather sensor	Solar panel (built-in)
7-in-1 weather sensor (backup)	2 x AA 1.5V LR6 Alkaline (not included), or 2 x AA 1.5V Lithium battery (not included)

**Table 5: Power specification**

The primary power source for the outdoor sensor is the solar panel. When available solar power (light over recent period) is insufficient, the batteries will be used. In outdoor climates that frequently have sustained temperatures below 0°C (or 32°F) the use of Lithium batteries is strongly suggested as these are performing better than Alkaline batteries under such circumstances.

## **9 Warranty Information**

**We disclaim any responsibility for any technical error or printing error, or the consequences thereof.**

**All trademarks and patents are recognized.**

We provide a 1-year limited warranty on this product against manufacturing defects, or defects in materials and workmanship.

This limited warranty begins on the original date of purchase, is valid only on products purchased, and only to the original purchaser of this product. To receive warranty service, the purchaser must contact us for problem determination and service procedures.

This limited warranty covers only actual defects within the product itself and does not cover the cost of installation or removal from a fixed installation, normal set-up or adjustments, or claims based on misrepresentation by the seller, or performance variations resulting from installation-related circumstances.