

WiFi Weather Station

Operation Manual

Model: WN1980

Table of Contents

1 Features	3
2 Specificatio.....	4
3 Connection between console and Wi-Fi Router	4
4 Power on.....	5
4.1 Initial Display Console Set Up.....	5
4.2 Screen Display	7
5 Key	8
5.1 Key function.....	8
5.2 Setting mode	9
5.3 Barometric Pressure Display	12
5.3.1 Viewing Absolute vs. Relative Pressure.....	12
5.3.2 Rate of Change of Pressure Graph.....	12
5.3.3 Relative Pressure Calibration Discussion	12
5.4 Rain Display.....	13
5.4.1 Rain Increments of Measure	13
5.4.2 Increments of Rain Definitions	13
5.5 Wind Display.....	14
5.6 Temperature Display	14
5.6.1 Wind Chill, Dew Point and Heat Index Display	14
5.7 Alarms	14
5.7.1 Viewing High and Low Alarms.....	15
5.7.2 Setting High and Low Alarms.....	15
5.8 Max/Min Mode	19
5.8.1 Viewing Max/Min Values.....	19
5.9 Resynchronize Wireless Sensor	20
5.10 Backlight Operation	21
5.10.1 With USB cable (included)	21
5.10.2 Without USB cable.....	21
5.11 Tendency Arrows.....	21
5.12 Wireless Signal Quality Indicator.....	21
5.13 Weather Forecasting	22
5.13.1 Storm Alert.....	22
5.13.2 Weather Forecasting Description and Limitations	23
6 Install & Wireless Communication	23
7 Troubleshooting Guide.....	24
8 Warranty Information	26



* Please scan the QR code to read English manual and keep it for future reference

* Bitte scannen Sie den QR-Code zudeutsche Anleitung lesen und aufbewahren für Zukunftsbezug

* Si prega di scansionare il codice QR per leggere il manuale italiano e conservarlo per futura riferimento

Instruction manuals

<https://s.ecowitt.com/BHGPPM>

Help

Our product is continuously changing and improving, particularly online services and associated applications. To download the latest manual and additional help, please contact our technical support team:

support@ecowitt.com

support.eu@ecowitt.net (EU/UK)



MADE IN CHINA

AC WORKS CONSULTING Srl
Via Vilfredo Pareto 125,47521
Casena(FC),ITALY

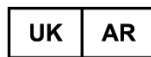

HUA TENG LIMITED
3 Glass Street, Hanley, Stoke On Trent,
ST1 2ET United Kingdom

1 Features

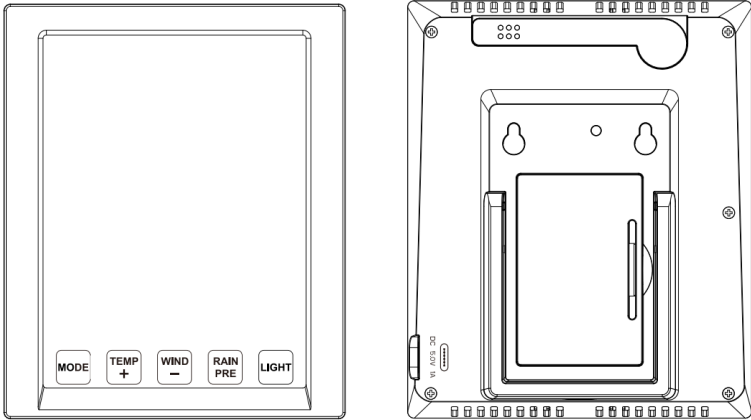

Figure 1: Display console front and back

- (1) Touch Key
- (2) Wi-Fi ready, works with ecowitt weather service, WU, WOW and custom server
- (3) Sharp LCD display
- (4) All ecowitt ecosystem sensors are supported for uploading to cloud server, and on LCD it displays data for wind, rain, outdoor temperature and humidity only. Those undisplay data can be viewed via ecowitt APP or website dashboard.
- (5) Additional/optional sensors:
 - Up to 8 WH31 multi-channel temperature and humidity sensors Or 8 WN30 multi-channel temp sensors Or WN36 Pool Thermometer
 - Up to 8 WN34 Temperature Sensors
 - Up to 8 WN35 Leaf Wetness Sensor
 - Up to 4 WH41/WH43 PM2.5 air quality sensors
 - One WH45 PM2.5/PM10/CO2/temperature and humidity all-in-1 sensor
 - Up to 8 WH51 soil moisture sensors
 - Up to 4 WH55 water leak sensors

- One WH57 lightning sensor
- One WH68 4-in-1 sensor Indoor temperature, indoor humidity, wind direction and wind speed
- One WN67 Outdoor Sensor Body with built-in: Thermo-hygrometer / Rain Gauge / Wind Speed Sensor/ Wind Direction Sensor
- One WS69 Outdoor Sensor Body with built-in: Thermo-hygrometer / Rain Gauge / Wind Speed Sensor/ Wind Direction Sensor, Light and UV sensor, Solar panel
- One WS80 Ultrasonic Anemometers with Temp & Humidity sensor
- One WS90 Ultrasonic Anemometer with Piezoelectric Rain Gauge, Light & UV, Thermo-hygrometer Sensors

2 Specifications

Measurement	Range	Accuracy	Resolution
Barometric	300 to 1100 hPa (8.85 to 32.5 inHg)	± 5hPa	0.1hPa (0.01 inHg)
Temperature (Indoor)	-10°C to 60°C (- 14°F to 140°F)	± 0.3°C (± 0.6°F)	0.1°C (0.1°F)
Humidity (Indoor)	1% to 99%	± 3.5%	1%

Power supply: Type-C power cable

Backup power: 2 x AA batteries (Support Min. 48 hours working)

3 Connection between console and Wi-Fi Router

Transmission distance in open field: 30m (100ft.) depending on router and environment

Wi-Fi Frequency: 2.4 GHz

WLAN: 802.11 b/g/n

4 Power on

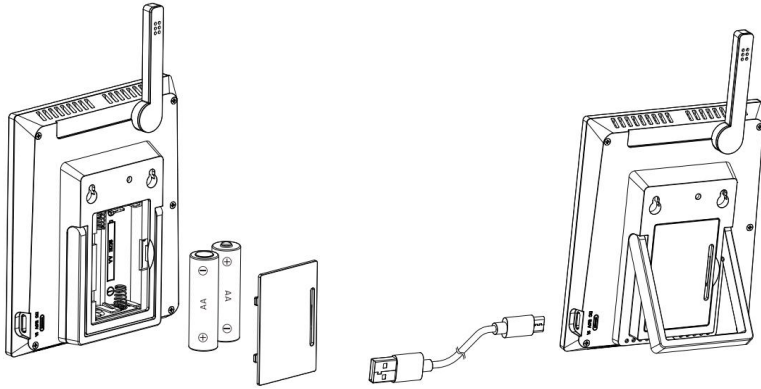

Figure 2: Batteries or USB cord

- (1) Unfold the desk stand and place it 5 to 10 feet away from the outdoor sensor.
- (2) Remove the battery door and insert 2 AA Alkaline batteries. Then plug in USB cord for normal operation. Please note the primary use of battery is for power cut back up purpose only, and always the console need to be powered via USB power.
- (3) Wait several minutes for the remote sensors to synchronize with the display console.
- (4) During normal operation, console will generate heat and cause temperature rising. To prevent this heat up, the temperature and humidity sensor is located at the foldable probe ends. To achieve maximum accuracy reading, please unfold the probe and make sure the sensor is further away from the main console body.

4.1 Initial Display Console Set Up

Upon power up the display console:

The unit will show sensor frequency under the wind direction graph and software version number 2 seconds.

Then all segments of the LCD will be on for 3 seconds: check all LCD segments are displayed correctly. After this, the unit will start to register sensors for 3 minutes.

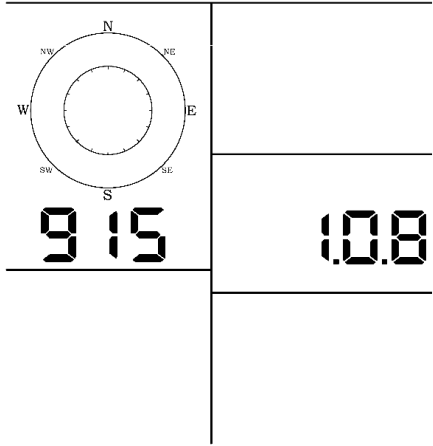

Figure 3: Display Console Screen Layout

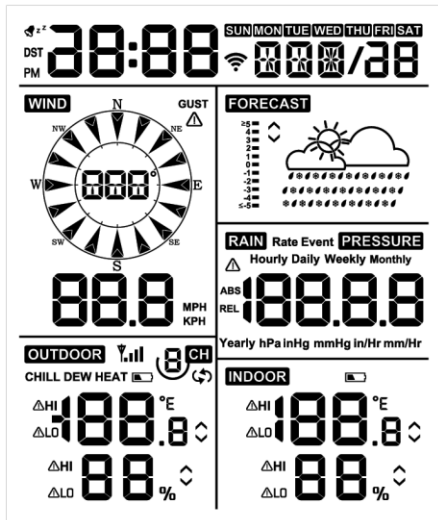

Figure 4: Display Console Screen Layout

4.2 Screen Display

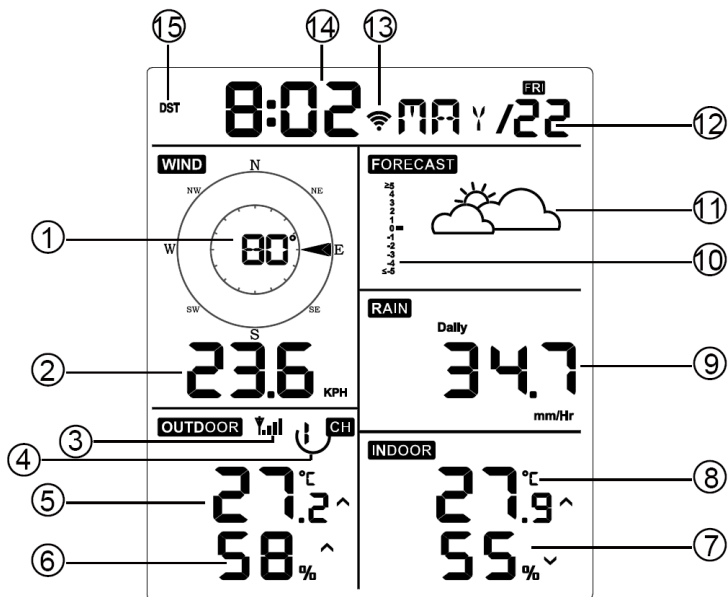

Figure 5: Display Console Screen Layout

1	Wind direction	9	Rainfall
2	Wind speed	10	Barometric Pressure graphic
3	RF icon	11	Weather forecast
4	8 Channel Indoor/Outdoor Thermo-Hygrometer recycle icon (optional)	12	Date
5	Outdoor temperature	13	WIFI icon
6	Outdoor humidity	14	Time
7	Indoor humidity	15	Daylight Savings Time (DST)
8	Indoor temperature		

Table 1: Display console detailed items

5 Key

5.1 Key function

The console has five keys for easy operation

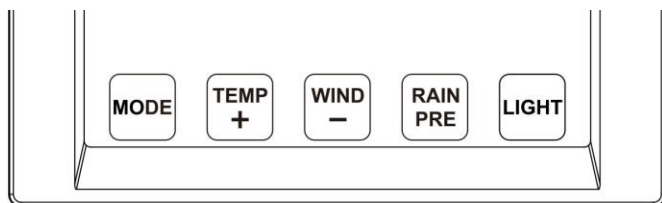

Figure 6

Key	Description
MODE	<ul style="list-style-type: none">• Press and hold for two seconds to enter the Set Mode.• Press to switch between Normal Mode, Max Mode, Min Mode, High Alarm Mode, Low Alarm Mode, MAC address display Mode
TEMP+	<ul style="list-style-type: none">• Press to switch between Outdoor Temperature, Wind Chill, Dew Point, Heat Index, 8 channel optional Indoor/Outdoor Thermo-hygrometer, Circle Mode
WIND -	<ul style="list-style-type: none">• Press to switch between average wind speed and, wind gust.• Press and hold for two seconds to switch the wind direction to display in degrees or in letters.
RAIN/PRE	<ul style="list-style-type: none">• Press and hold for two seconds switch between Rain and Barometer.• While in Rain mode, press to switch between Rain Rate, Rain Events, Hourly Rain, Daily Rain, Weekly Rain, and Monthly Rain• While in Pressure mode, press to switch between Relative pressure and Absolute pressure
LIGHT	<ul style="list-style-type: none">• Press to adjust the LCD backlight brightness (high, medium and off).• Press to exit the SET mode at any time.

TEMP+ (and) RAIN PRE	<ul style="list-style-type: none"> • Press these two buttons at the same time for 4 seconds to activate Wi-Fi configuration mode (refer to section 8.1.2)
---	--

Table 2: Key function



5.2 Setting mode



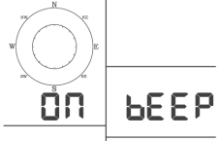
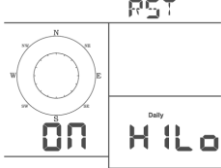

Note: DST, Time Zone setting can only be realized via ECOWITT APP. You will need to set time zone and DST properly if you have the console connected to internet.

Press and hold the **MODE** button for two seconds to enter the Set Mode. To proceed to the next setting, press (do not hold) the **MODE** button.

To exit the SET mode at any time, press the **LIGHT** button.

错误!未找到引用源。 summarizes the set mode sequence and commands.

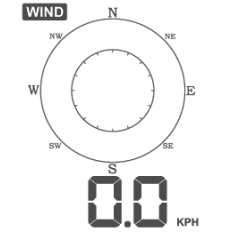
Command	Mode	Settings	Image
[MODE] + 2 seconds	Enter Set Mode, Beep On or Off	Press [TEMP +] or [WIND -] to switch OFF and ON. This will prevent the beep from sounding when pressing any button.	
[MODE]	Clear Max/Min	Press [TEMP +] or [WIND -] to switch OFF and ON. When set to ON, the minimum and maximum values reset every day at midnight (00:00). When set to OFF, the minimum and maximum values must be reset manually.	
[MODE]	12 hour / 24 Hour Format	Press [TEMP +] or [WIND -] to switch hour format between 12 hour and 24-hour format.	
[MODE]	Hour	Press [TEMP +] or [WIND -] to adjust hour up or down.	
[MODE]	Minute	Press [TEMP +] or [WIND -] to adjust minute up or down.	
[MODE]	Year	Press [TEMP +] or [WIND -] to adjust year up or down	
[MODE]	Month	Press [TEMP +] or [WIND -] to adjust month up or down	

[MODE]	Day	Press [TEMP +] or [WIND -] to adjust day up or down	
[MODE]	Pressure Units of Measure	Press [TEMP +] or [WIND -] to change units of measure between hPa, mmHg or inHg.	
[MODE]	Relative Pressure Calibration	Press [TEMP +] or [WIND -] to adjust relative pressure up or down Reference Section 03 for details on calibration of relative pressure.	
[MODE]	Temperature Units of Measure	Press [TEMP +] or [WIND -] to change temperature units of measure between °F and °C.	
[MODE]	Wind Units of Measure	Press [TEMP +] or [WIND -] to change wind units of measure between km/h and mph.	
[MODE]	Rain Units of Measure	Press [TEMP +] or [WIND -] to change rain units of measure between in and mm.	
[MODE]	Exit Set Mode		

[MODE] + 2 seconds means press and hold the MODE button for two seconds.

[MODE] means press the MODE button.

Table 3: Set mode sequence and commands summarization

5.3 Barometric Pressure Display

5.3.1 Viewing Absolute vs. Relative Pressure

Press and hold [RAIN/PRE] for two seconds switch between Rain and Pressure. While in Pressure mode Press [RAIN/PRE] to switch between absolute and relative pressure

Absolute pressure is the measured atmospheric pressure, and is a function of altitude, and to a lesser extent, changes in weather conditions.

Absolute pressure is not corrected to sea-level conditions.

Relative pressure is corrected to sea-level conditions. For further discussion of relative pressure and calibration, reference Section 0.

5.3.2 Rate of Change of Pressure Graph

The rate of change of pressure graphic is shown to the left of the weather forecast icons and signifies the difference between the daily average pressure and the 30-day average (in hPa).



Figure 7

5.3.3 Relative Pressure Calibration Discussion

The calibration can be realized on ECOWITT app by going to “sensor” page, and you can find the console of WN1980 to start with. To compare

pressure conditions from one location to another, meteorologists correct pressure to sea-level conditions. Because the air pressure decreases as you rise in altitude, the sea-level corrected pressure (the pressure your location would be at if located at sea-level) is generally higher than your measured pressure.

Thus, your absolute pressure may read 28.62 inHg (969 mb) at an altitude of 1000 feet (305 m), but the relative pressure is 30.00 inHg (1016 mb).

The standard sea-level pressure is 29.92 inHg (1013 mb). This is the average sea-level pressure around the world. Relative pressure measurements greater than 29.92 inHg (1013 mb) are considered high pressure and relative pressure measurements less than 29.92 inHg are considered low pressure.

To determine the relative pressure for your location, locate an official reporting station near you (the internet is the best source for real time barometer conditions, such as Weather.com or Wunderground.com), and set your weather station to match the official reporting station.

5.4 Rain Display

5.4.1 Rain Increments of Measure

Press and hold [RAIN/PRE] for two seconds switch between Rain and Pressure. While in Rain mode press [RAIN/PRE] button to switch between Rain Rate (in/hr), Rain Event, Rain Hourly, Daily Rain, Weekly Rain, Monthly Rain and Yearly Rain.

5.4.2 Increments of Rain Definitions

- **Rain rate or hourly rain** is defined as the last 10 minutes of rainfall sum total and multiplied by six (10 minutes x 6 = 1 hour). This is also referred to as instantaneous rain per hour.
- **Rain event** is defined as continuous rain, and resets to zero if rainfall accumulation is less than 1 mm (0.039 in) in a 24-hour period.
- **Daily Rain** is defined as the rainfall since midnight (00:00).
- **Weekly Rain** is defined as the calendar week total and resets on

Sunday morning at midnight (Sunday thru Saturday).

- **Monthly Rain** is defined as the calendar month total and resets on the first day of the Month.
- **Yearly Rain** is defined as the calendar year i.e. January 1- December 31

5.5 Wind Display

Press the [WIND -] button to switch between average wind speed and, wind gust.

Press and hold the [WIND -] button for two seconds to switch the wind direction to display in degrees or in letters.

- **Wind speed** is defined as the average wind speed in the 16 second update period.
- **Wind gust** is defined as the peak wind speed in the 16 second update period.

5.6 Temperature Display

If temperature is lower than minimum range, the temperature field will display dashes (---).

If temperature is higher than maximum range, the temperature field will display dashes (---).

5.6.1 Wind Chill, Dew Point and Heat Index Display

Press the [TEMP] button to switch between Outdoor Temperature, Wind Chill, Dew Point, Heat Index.

The device supports up to 8 additional thermo-hygrometer sensors (WH31). If you have the extra sensors, press the [TEMP+] button to switch between Outdoor Temperature, Wind Chill, Dew Point, Heat Index, 8 channel temperature and humidity, Circle Mode

5.7 Alarms

5.7.1 Viewing High and Low Alarms

To view the high alarm settings, press **MODE** button a third time, and the high alarms will be displayed, as shown in 错误!未找到引用源。 (a).

To view the low alarm settings, press the **MODE** button a fourth time, and the low alarms will be displayed, as shown in 错误!未找到引用源。 (b).

To return to normal mode, press the **LIGHT** button again.

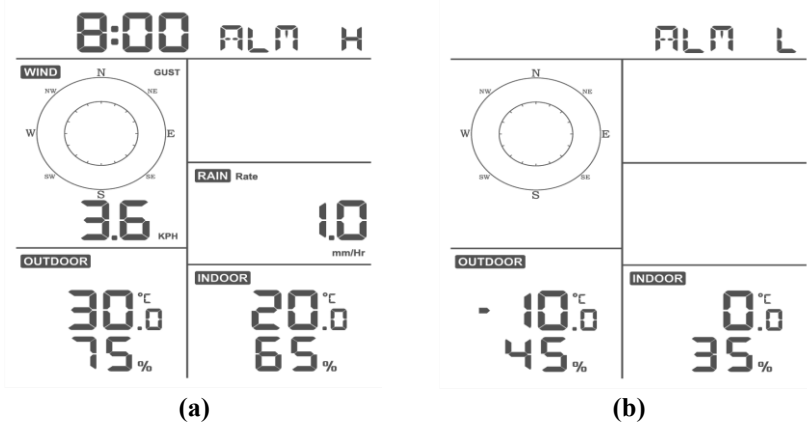

Figure 8

5.7.2 Setting High and Low Alarms





While the High Alarm is displayed (reference Section 错误!未找到引用源。), press and hold the **MODE** button for 2 seconds to enter the High Alarm Set Mode.





While the Low Alarm is displayed (reference Section 错误!未找到引用源。), press and hold the **MODE** button for 2 seconds to enter the Low Alarm Set Mode.





To save and proceed to the next alarm setting, press the **Mode** button.

To exit the High Alarm Set Mode at any time, press the **LIGHT** button.

错误!未找到引用源。 summarizes the alarm mode sequence and commands.

<p>[MODE] + 2 seconds</p>	<p>Enter High Alarm Set Mode, Alarm Hour</p>	<p>Press [TEMP +] or [WIND -] to adjust alarm hour up or down.</p> <p>Press [RAIN/PRE] to turn the time alarm on or off. When the alarm is on, the alarm time icon  will appear.</p>
<p>[MODE]</p>	<p>Alarm Minute</p>	<p>Press [TEMP +] or [WIND -] to adjust alarm minute up or down.</p> <p>Press [RAIN/PRE] to turn the time alarm on. The alarm time icon  will appear.</p> <p>Press [RAIN/PRE] again to turn the time alarm off. The alarm time icon will disappear.</p>
<p>[MODE]</p>	<p>Alarm High Indoor Temperature</p>	<p>Press [TEMP +] or [WIND -] to adjust alarm value up or down.</p> <p>Press [RAIN/PRE] to turn the alarm on. The alarm icon  HI will appear.</p> <p>Press [RAIN/PRE] to turn the alarm off. The alarm icon will disappear.</p>
<p>[MODE]</p>	<p>Alarm High Indoor Humidity</p>	<p>Press [TEMP +] or [WIND -] to adjust alarm value up or down.</p> <p>Press [RAIN/PRE] to turn the alarm on. The alarm icon  HI will appear.</p> <p>Press [RAIN/PRE] to turn the alarm off. The alarm icon will disappear.</p>

<p>[MODE]</p>	<p>Alarm High Outdoor Temperature</p>	<p>Press [TEMP +] or [WIND -] to adjust alarm value up or down.</p> <p>Press [RAIN/PRE] to turn the alarm on. The alarm icon  HI will appear.</p> <p>Press [RAIN/PRE] to turn the alarm off. The alarm icon will disappear.</p>
<p>[MODE]</p>	<p>Alarm High Outdoor Humidity</p>	<p>Press [TEMP +] or [WIND -] to adjust alarm value up or down.</p> <p>Press [RAIN/PRE] to turn the alarm on. The alarm icon  HI will appear.</p> <p>Press [RAIN/PRE] to turn the alarm off. The alarm icon will disappear.</p>
<p>[MODE]</p>	<p>Alarm High Wind Gust</p>	<p>Press [TEMP +] or [WIND -] to adjust alarm value up or down.</p> <p>Press [RAIN/PRE] to turn the alarm on. The alarm icon  HI will appear.</p> <p>Press [RAIN/PRE] to turn the alarm off. The alarm icon will disappear.</p>
<p>[MODE]</p>	<p>Alarm High Rain Rate</p>	<p>Press [TEMP +] or [WIND -] to adjust alarm value up or down.</p> <p>Press [RAIN/PRE] to turn the alarm on. The alarm icon  HI will appear.</p> <p>Press [RAIN/PRE] to turn the alarm off. The alarm icon will disappear.</p>

[MODE]	Alarm Low Indoor Temperature	<p>Press [TEMP +] or [WIND -]to adjust alarm value up or down.</p> <p>Press [RAIN/PRE] to turn the alarm on. The alarm icon  will appear.</p> <p>Press [RAIN/PRE] to turn the alarm off. The alarm icon will disappear.</p>
[MODE]	Alarm Low Indoor Humidity	<p>Press [TEMP +] or [WIND -] to adjust alarm value up or down.</p> <p>Press [RAIN/PRE] to turn the alarm on. The alarm icon  will appear.</p> <p>Press [RAIN/PRE] to turn the alarm off. The alarm icon will disappear.</p>
[MODE]	Alarm Low Outdoor Temperature	<p>Press[TEMP +] or [WIND -] to adjust alarm value up or down.</p> <p>Press [RAIN/PRE] to turn the alarm on. The alarm icon  will appear.</p> <p>Press [RAIN/PRE] to turn the alarm off. The alarm icon will disappear.</p>
[MODE]	Alarm Low Outdoor Humidity	<p>Press [TEMP +] or [WIND -] to adjust alarm value up or down.</p> <p>Press [RAIN/PRE] to turn the alarm on. The alarm icon  will appear.</p> <p>Press [RAIN/PRE] to turn the alarm off. The alarm icon will disappear.</p>
[MODE]	Exit alarm settings mode.	

[MODE] + 2 seconds means press and hold the ALARM button for 2

seconds.

[MODE] means press the MODE button.

Table 4: Alarm mode sequence and commands summarization

5.8 Max/Min Mode

5.8.1 Viewing Max/Min Values

To view the max value, press the **MODE** button, and the max values will be displayed, as shown in 错误!未找到引用源。 (a). To clear the max values, press and hold the MODE button while the max values are displayed.

To view the low alarm settings, press the **MODE** button again, and the min values will be displayed, as shown in 错误!未找到引用源。 (b). To clear the min values, press and hold the MODE button while the min values are displayed.

To return to normal mode, press the **LIGHT** button.

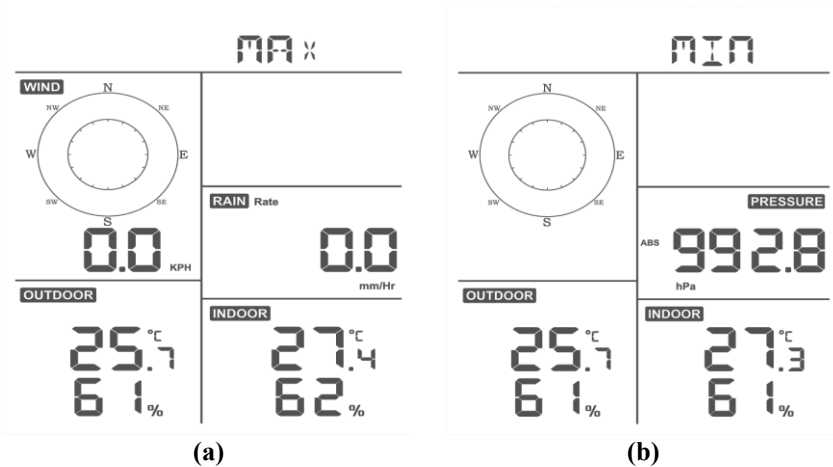

Figure 9

5.8.1.1 Display Wind Chill, Heat Index vs. Dew Point Max/Min Values

While the **max values** are displayed as outlined in Section 错误!未找到引用源。 , press the **TEMP+** button once to view the wind chill, twice to view the dew point, third to view the heat index and a fourth time to return to outdoor temperature.

While the **min values** are displayed as outlined in Section 错误!未找到引用源。 , press the **TEMP+** button once to view the wind chill, twice to view the dew point, third to view the heat index and a fourth time to return to outdoor temperature.

5.8.1.2 Display Wind Speed vs. Wind Gust Max Values

While the **max values** are displayed as outlined in Section 错误!未找到引用源。 , press the **WIND-** button once to view the max wind gust, and twice to return to wind speed.

5.8.1.3 Display Hourly Rain, Rain Rate

While the **max values** are displayed as outlined in Section 错误!未找到引用源。 , press the **RAIN** button once to view the max hourly rain, twice to view the rain rate.

5.8.1.4 Display Absolute and Relative Pressure Min and Max Values

While the **max values** are displayed as outlined in Section 错误!未找到引用源。 , press and hold the **RAIN/PRE** button for two seconds to enter pressure display, press **RAIN/PRE** button to switch between Relative pressure and Absolute pressure.

While the **min values** are displayed as outlined in Section 错误!未找到引用源。 , press and hold the **RAIN/PRE** button for two seconds to enter pressure display, press **RAIN/PRE** button to switch between Relative pressure and Absolute pressure.

To return to normal mode, press the **LIGHT** button.

5.9 Resynchronize Wireless Sensor

While in outdoor TH/wind chill/dew point/heat index display mode press **TEMP+** button for 5 seconds, and the console will re-register the outdoor sensor array.

While in 1-8 channel Thermo-hygro sensor display mode press **TEMP+** button for 5 seconds, and the console will re-register the current channel outdoor sensor.

While in Circle Mode press **TEMP+** button for 5 seconds, and the console will re-register the sensor array and 1-8 channel sensors.

5.10 Backlight Operation

5.10.1 With USB cable (included)

The backlight can only be continuously on when the console display is powered via USB.

Press the **LIGHT** button to adjust the brightness between High, Low and Off.

5.10.2 Without USB cable

Press any button to turn on the backlight temporarily for 15 seconds.

5.11 Tendency Arrows

Tendency arrows allow you to quickly determine if temperature or pressure are rising and falling in a three-hour update period, updated every 30 minutes.

Table 10 defines the conditions for rising and falling pressure every 3 hours.

Tendency indicators	Condition	Humidity Change per 3 Hours	Temperature Change per 3 Hours
∧	Rising	Rising > 3%	Rising > 1° C / 2 °F
∨	Falling	Falling > 3%	Falling > 1° C / 2 °F

Table 5: Tendency indicators summarization

5.12 Wireless Signal Quality Indicator

The wireless signal strength displays reception quality. If no signal is lost, the signal strength indicator will display 4 bars. If the signal is lost once, four bars will be displayed, as shown in 错误!未找到引用源。 .







Four Bars	Three Bars
	
No signal loss	Lost signal once

Table 6

5.13 Weather Forecasting

The five weather icons are Sunny, Partly Cloudy, Cloudy, Rainy, Stormy and Snowy.

The forecast icon is based on the rate of change of barometric pressure. Please allow at least **one month** for the weather station to learn the barometric pressure over time.

Sunny	Partly Cloudy	Cloudy	Rainy	Snowy
				

Pressure increases for a sustained period of time	Pressure increases slightly, or initial power up	Pressure decreases slightly	Pressure decreases for a sustained period of time	Pressure decreases for a sustained period of time and temperature is below freezing
---	--	-----------------------------	---	---

Table 7: Weather forecasting summarization

5.13.1 Storm Alert

If there is a rapid drop in barometric pressure, the forecast icon will flash.

5.13.2 Weather Forecasting Description and Limitations

In general, if the rate of change of pressure increases, the weather is generally improving (sunny to partly cloudy). If the rate of change of pressure decreases, the weather is generally degrading (cloudy, rainy). If the rate of change is relatively steady, it will read partly cloudy.

The reason the current conditions do not match the forecast icon is because the forecast is a prediction 24-48 hours in advance. In most locations, this prediction is only 70% accurate and it is a good idea to consult the National Weather Service for more accurate weather forecasts. In some locations, this prediction may be less or more accurate. However, it is still an interesting educational tool for learning why the weather changes.

The National Weather Service (and other weather services such as Accuweather and The Weather Channel) have many tools at their disposal to predict weather conditions, including weather radar, weather models, and detailed mapping of ground conditions.

6 Install & Wireless Communication



Note: To insure proper communication, mount the remote sensor(s) upright on a vertical surface, such as a wall. **Do not lay the sensor flat.**

Wireless communication is susceptible to interference, distance, walls and metal barriers. We recommend the following best practices for trouble free wireless communication.

Electro-Magnetic Interference (EMI). Keep the console several feet away from computer monitors and TVs.

Radio Frequency Interference (RFI). If you have other devices operating on the same frequency band as your indoor and/or outdoor sensors and experience intermitted communication between sensor and console, try turning off these other devices for troubleshooting purposes. You may need to relocate the transmitters or receivers to avoid intermittent communication.

1. **Line of Sight Rating.** This device is rated at 300 feet line of sight (no interference, barriers or walls) but typically you will get 100 feet maximum under most real-world installations, which include passing through barriers or walls.
2. **Metal Barriers.** Radio frequency will not pass through metal barriers such as aluminum siding. If you have metal siding, align the remote and console through a window to get a clear line of sight.

The following is a table of reception loss vs. the transmission medium. Each “wall” or obstruction decreases the transmission range by the factor shown below.

Medium	RF Signal Strength Reduction
Glass (untreated)	5-15%
Plastics	10-15%
Wood	10-40%
Brick	10-40%
Concrete	40-80%
Metal	90-100%

Table 8: RF Signal Strength reduction

7 Troubleshooting Guide

Problem	Solution
<p>Outdoor sensor array does not communicate to the display console.</p>	<p>The sensor array may have initiated properly and the data is registered by the console as invalid, and the console must be reset. Press the reset button as described in Section 5.2.</p> <p>With an open ended paperclip, press the reset button for 3 seconds to resync the console with the sensor array about 10 feet away.</p> <p>The LED next to the battery compartment will flash every 16 seconds. If the LED is not flashing every 16 seconds...</p> <p>Replace the batteries in the outside sensor array.</p> <p>If the batteries were recently replaced, check the polarity. If the sensor is flashing every 16 seconds, proceed to the next step.</p> <p>There may be a temporary loss of communication due to reception loss related to interference or other location factors,</p> <p>or the batteries may have been changed in the sensor array and the console has not been reset. The solution may be as simple as powering down and up the console (remove AC power and batteries, wait 10 seconds, and reinsert AC power and batteries).</p>
<p>Temperature sensor reads too high in the day time.</p>	<p>Make certain that the sensor array is not too close to heat generating sources or structures, such as buildings, pavement, walls or air conditioning units.</p> <p>Use the calibration feature to offset installation issues related to radiant heat sources. Reference Section 10.6.</p>

Problem	Solution
Relative pressure does not agree with official reporting station	<p>You may be viewing the absolute pressure, not the relative pressure.</p> <p>Select the relative pressure. Make sure you properly calibrate the sensor to an official local weather station. Reference Section 6.4.3 for details.</p>
No WiFi connection	<ol style="list-style-type: none"> 1. Check for WiFi symbol on the display. If wireless connectivity is successful the WiFi icon  will be displayed in the time field. 2. Make sure your modem WiFi settings are correct (network name, and password). 3. The console only supports and connects to 2.4 GHz routers. If you own a 5 GHz router, and it is a dual band router, you will need to disable the 5 GHz band, and enable the 2.4 GHz band. 4. The console does not support guest networks.

8 Warranty Information

We disclaim any responsibility for any technical error or printing error, or

their consequences.

All trademarks and patents are recognized.

We provide a 1-year limited warranty on this product against manufacturing defects in materials and workmanship.

This limited warranty begins on the original date of purchase, is valid only on products purchased and only to the original purchaser of this product. To receive warranty service, the purchaser must contact us for problem determination and service procedures.

This warranty covers only actual defects within the product itself, and does not cover the cost of installation or removal from a fixed installation, normal set-up or adjustments, claims based on misrepresentation by the seller or performance variations resulting from installation-related circumstances.